

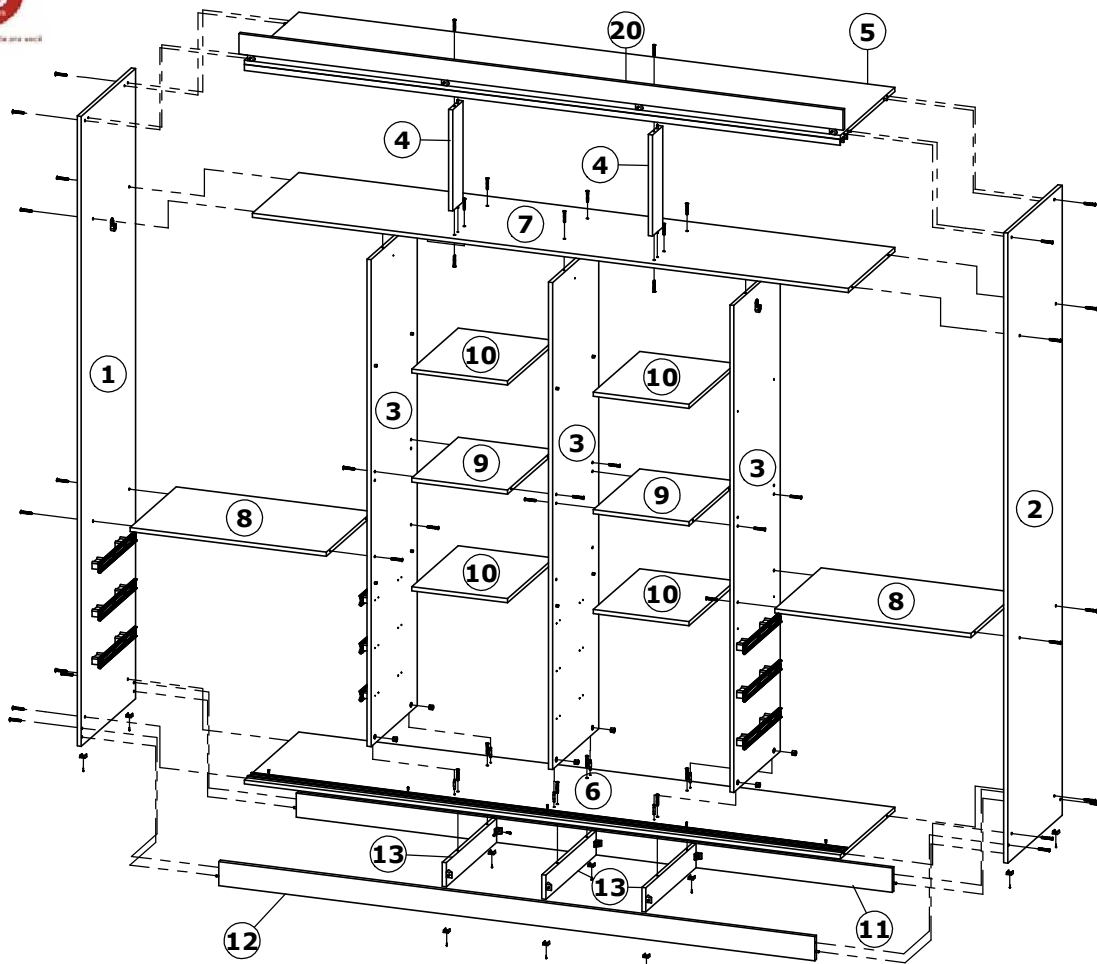

Roupeiro Málaga 2P | Malaga 2P Wardrobe | Armario Málaga 2P

Faça o seu pedido antes das 18h



Cod. Qnt.

A 6	B 8	C 246	D 48	E 39	F 24	G 6	H 6	I 60
J 180	K 71	L 10	M 24	N 10	O 4	P 3	Q 16	R 6
S 38	T 8	U 12	V 24	W 1	X 1	Y 2	Z 2	AA 6
AB 6	AC 2	AD 2	AE 2	Kit Sistema Correr cod. 35766				

Montagem Gavetas

quarta-feira, 27 de agosto de 2025

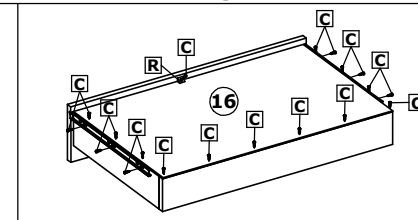
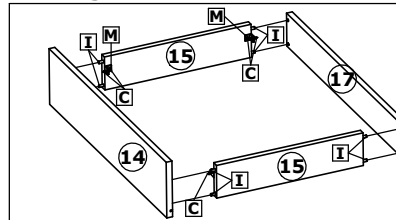

Roupeiro Málaga Capuccino

Peça Pieza	Cod.	Descrição	Description	Descripción	Qtde Qty Cant	Compr Length Largo	Larg. Width Ancho	Esp. Thickness Espesor
1	P20045	Lateral Esquerda	Left Panel	Lateral Izquierda	1	2298	528	15
2	P20044	Lateral Direita	Right Panel	Lateral Derecha	1	2298	528	15
3	P20046	Divisão Esq/Dir	Left/Right Side Division	Division Izq/Der	3	1776	450	15
4	P20097	Divisão Maleiro	Division	Division	2	369	100	15
5	P20050	Tamos Superior	Top	Tapa Superior	1	2191	528	15
6	P20049	Tampo Inferior	Top	Tapa Inferior	1	2191	528	15
7	P20051	Tampo Intermediário	Intermediate Top	Tapa Intermediaria	1	2191	450	15
8	P20052	Tampo Sup. Gaveta	Top Drawer Higher	Tapa Superior Cajón	2	721	450	15
9	P20053	Tampo Menor	Smaller Top	Tapa Pequeña	2	352	450	15
10	P20054	Prateleira	Shelf	Repisa	4	352	450	15
11	P20056	Traseiro Pé	Back Bottom Frame	Zocalo Traseiro	1	2191	88	15
12	P20055	Frente Pé	Bottom Frame	Marco Inferior	1	2191	88	15
13	P20057	Divisão Pé	Division Bottom Frame	Division Zocalo	3	489	88	15
14	P20060	Frente Gaveta	Drawer Frontal	Frente del Cajón	6	661	149	15
15	P18858	Lateral Gaveta	Side Drawer	Lat del Cajón	12	385	88	15
16	P20062	Fundo Gaveta	Bottom Drawer	Fondo del Cajón	6	644	406	2,5
17	P20059	Traseiro Gaveta	Rear Drawer	Traseo del Cajón	6	646	88	15
18	P20061	Fundo Vertical	Vertical Background	Fondo vertical	6	1800	366	2,5
19	P20149	Fundo Horizontal	Horizontal Background	Fondo Horizontal	1	2213	391	2,5
20	P20058	Moldura Superior	Top Frame	Marco Superior	1	2221	75	15

Roupeiro Málaga Capuccino C| Azul

21	P20047	Porta Azul	Door	Puerta	8	1085	532	15
----	--------	------------	------	--------	---	------	-----	----

Roupeiro Málaga Capuccino C| Off White

21	P20042	Porta Off White	Door	Puerta	8	1085	532	15
----	--------	-----------------	------	--------	---	------	-----	----

Espelhos Málaga Glass

22	39914	Espelho	Mirror	Espejo	2	1068	520	3
----	-------	---------	--------	--------	---	------	-----	---

Espelhos Málaga Full Glass

22	39914	Espelho	Mirror	Espejo	4	1068	520	3
----	-------	---------	--------	--------	---	------	-----	---



Atenção com a cor do acabamento!
Em caso de assistência solicitar o código de acordo com a cor da peça.
Pay attention to the color of the finish!
In case of assistance, request the code according to the color of the piece.
Presta atención al color del acabado!
En caso de asistencia solicitar el código según el color de la pieza.

Medidas em mm



Roupeiro Málaga 2P | Malaga 2P Wardrobe | Armario Málaga 2P

1º Passo / Step / Paso

Inicie a montagem da base, fixando as divisões pé (13) com parafusos D. Logo fixar traseiro pé (11) e frente pé (12) com cantoneira L e parafusos C.

Start the base assembly, securing the divisions Foot (13) with screws D. Logo fastening rear foot (11) and front foot (12) with Angle L and Screws C.

Inicie el montaje de la base, fijando las divisiones pie (13) con tornillos D. Logo fijar trasero pie (11) y frente pe (12) con cantonera L y tornillos C.

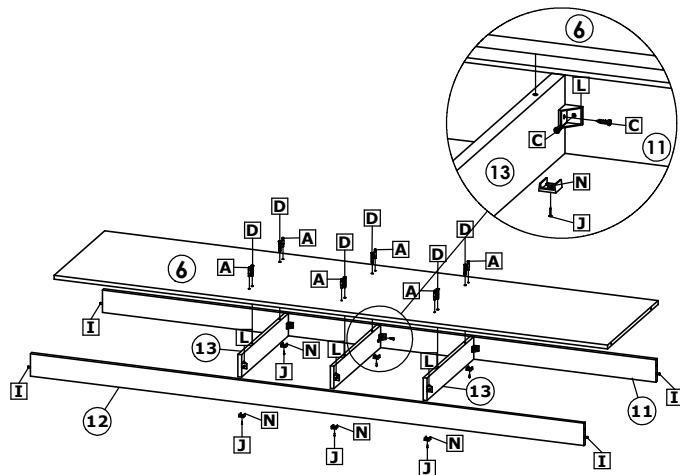

2º Passo / Step / Paso

Já com a base montada, fixe as divisões (3), com parafuso A e tambor G. Em seguida fixar as laterais (1, 2), tampo (8) e (9) com parafusos D.

Already with the base assembled, fix divisions (3), with screw A and drum G. Then fix the Sides (1, 2), Tops (8) and (9), with Screws D.

Con la base montada, fije las divisiones (3), con tornillo A y tambor G. A continuación fijar las laterales (1, 2) y Tapas (8) y (9) con tornillos D.

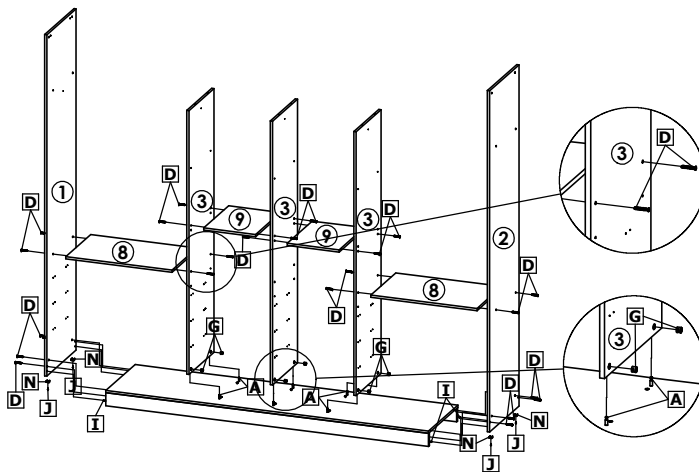

3º Passo / Step / Paso

Fixar a divisão maleiro (4), no tampo (7), com parafuso D e cavilha I. Isso deve ser feito antes de fixar o tampo (7), nas laterais (1, 2) e divisões (3).

Secure maleus division (4) on plate (7), with screw D and bolt I. This should be done before securing table (7), sides (1, 2) and divisions (3).

Fijar la división maleiro (4), en el tablero (7), con tornillo D y cuchillo I. Esto debe hacerse antes de fijar el tablero (7), en las laterales (1, 2) y divisiones (3).

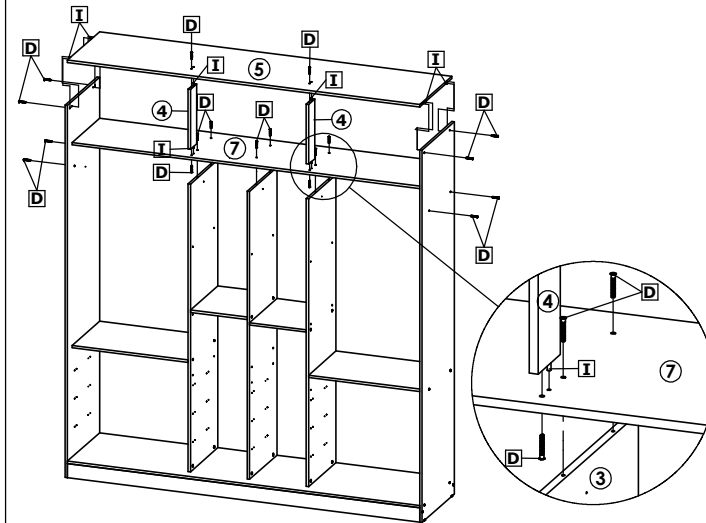

4º Passo / Step / Paso

O espaço entre um prego J e outro é de 100mm.
The space between one nail J and another is 100mm.
El espacio entre un clavo J y otro es de 100 mm.

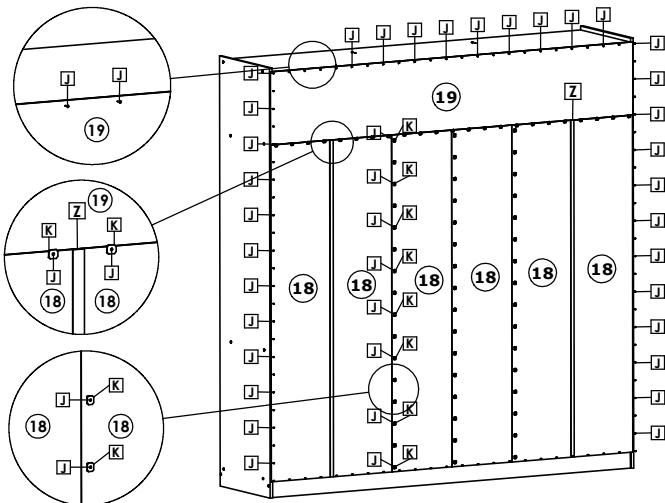

5º Passo / Step / Paso

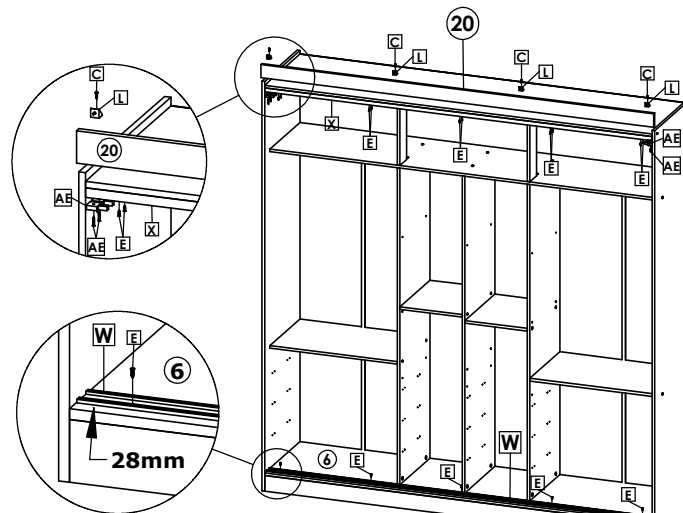

Fixar trilho inferior W com parafuso E, à 28mm da borda do tampo inferior (6).
Attach lower rail W with screw E, 28mm from bottom edge (6).

Fijar carril inferior W con tornillo E, a 28mm del borde del tablero inferior (6).

6º Passo / Step / Paso

Fixar correções AA nas laterais (1, 2), divisões (3), com parafusos C, E e distanciador V.

Fix slides AA to sides (1, 2), divisions (3), with screws C, E and spacer V.

Fije las correderas AA a los lados (1, 2), divisiones (3), con los tornillos C, E y el espaciador V.

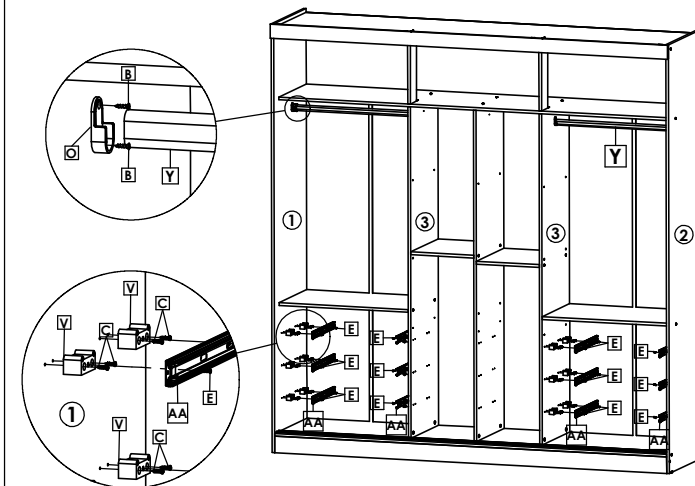

Roupeiro Málaga 2P | Malaga 2P Wardrobe | Armario Málaga 2P

7º Passo / Step / Paso

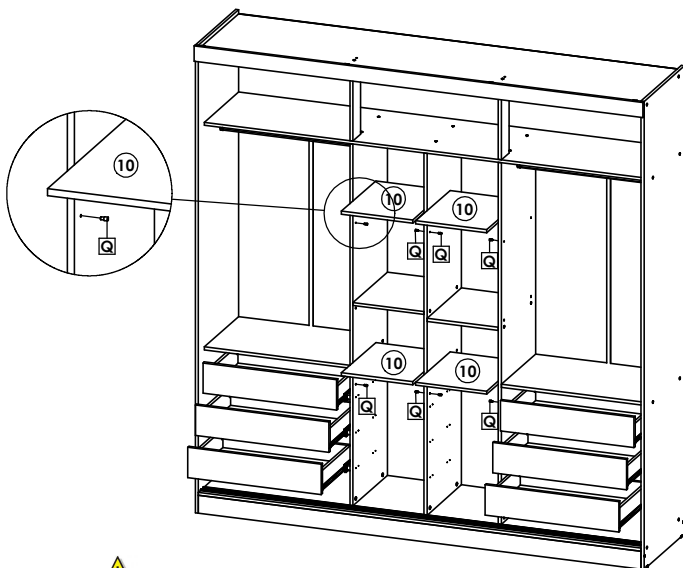

Colocação das gavetas e prateleiras.
Placement of drawers and shelves.
Colocação das gavetas e prateleiras.



Peso Suportado / Weight supported / peso que soporta.

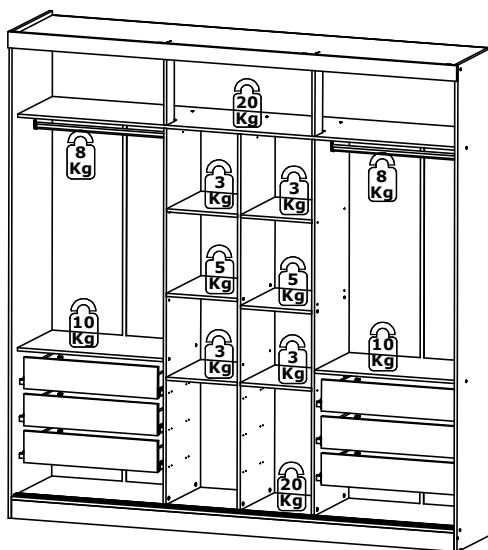

Peso suportado por gaveta.
Weight supported by drawer.
Peso suportado por cajón.



Montagem Portas | Doors Assembly | Montaje Puertas.



AS PORTAS DEVEM SER MANUSIADAS POR DUAS PESSOAS!!!
DOORS MUST BE HANDLED BY TWO PEOPLE!!!
LAS PUERTAS DEBEN SER MANIPULADAS POR DOS PERSONAS!!!

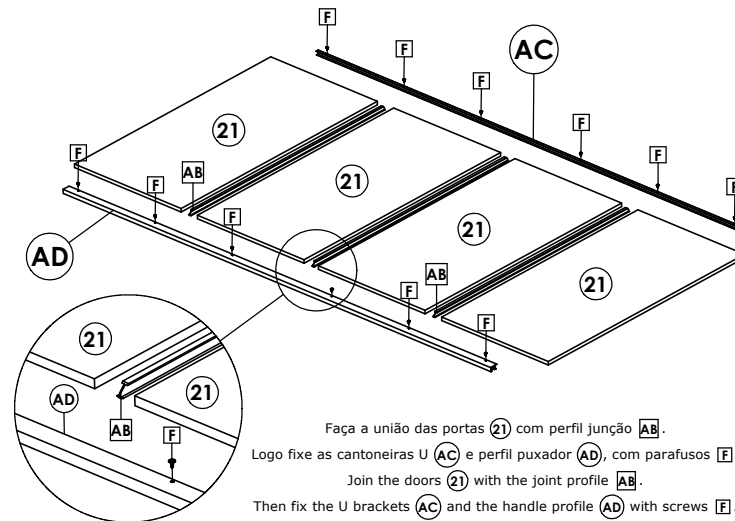

Faça a união das portas (21) com perfil junção (AB).
Logo fixe as cantoneiras U (AC) e perfil puxador (AD), com parafusos (F).
Join the doors (21) with the joint profile (AB).
Then fix the U brackets (AC) and the handle profile (AD) with screws (F).
Unir las puertas (21) con el perfil de unión (AB).
Luego fije los ángulos U (AC) y el perfil tirador (AD), con los tornillos (F).

Montagem Portas | Doors Assembly | Montaje Puertas.

Iniciar a montagem dos guias superiores (AE),
posicionando-os à 30mm do perfil puxador (AD) e da cantoneira U (AC), fixando-os com parafusos (AE).

Start assembling the upper guides (AE),
positioning them 30 mm from the pull profile (AD) and the U
bracket (AC), securing them with screws (AE).

Comience a ensamblar las guías superiores (AE),
colocándolos a 30mm del perfil tirador (AD) y del ángulo U (AC), fijándolos con tornillos (AE).

Posicionar o Rodízio Inferior (AE) à 32mm do perfil puxador (AD) e da Cantoneira U (AC).

Position Lower Caster (AE) 32mm from handle profile (AD) and U Bracket (AC).

Coloque la rueda inferior (AE) a 32 mm del perfil del mango (AD) y el ángulo U (AC).

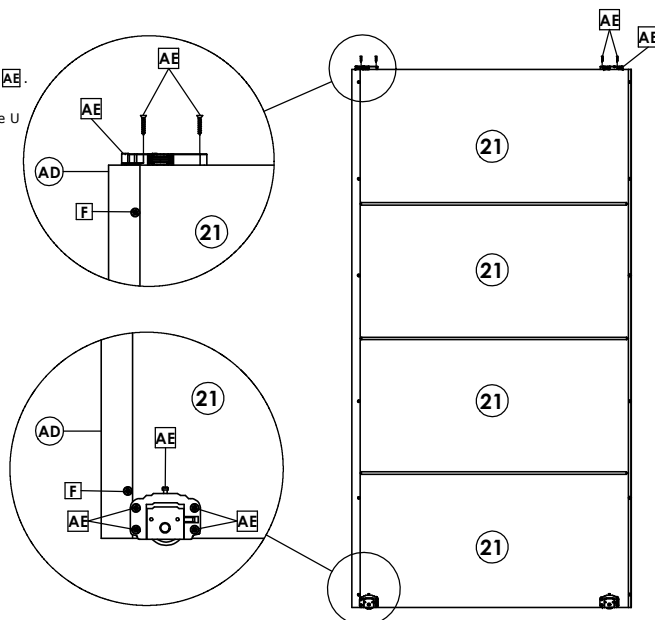

AS PORTAS DEVEM SER MANUSIADAS POR DUAS PESSOAS!!!
DOORS MUST BE HANDLED BY TWO PEOPLE!!!
LAS PUERTAS DEBEN SER MANIPULADAS POR DOS PERSONAS!!!

Montagem Portas | Doors Assembly | Montaje Puertas.

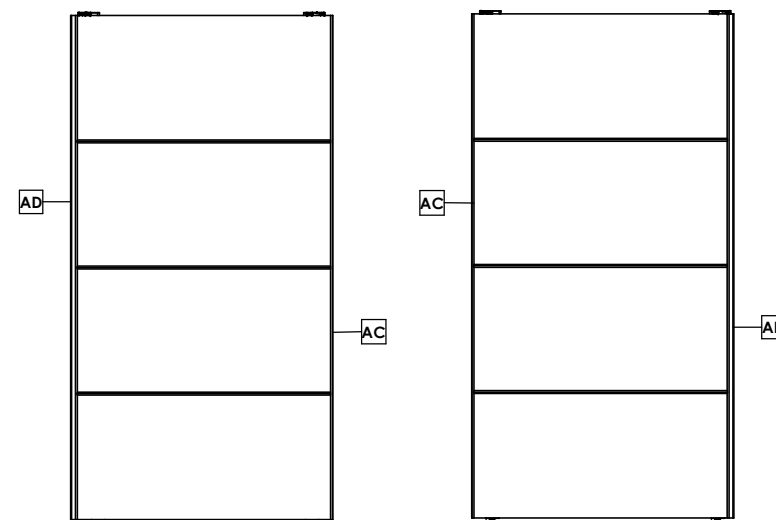

ATENÇÃO | ATTENTION | ATENCIÓN

Lembrando que o perfil puxador fica sempre para o lado da lateral do roupeiro, conforme imagem acima.
Remembering that the handle profile is always on the side of the wardrobe, as shown in the image above.
Recordando que el perfil tirador siempre queda hacia el lateral del armario, como se muestra en la imagen superior.

Roupeiro Málaga 2P | Malaga 2P Wardrobe | Armario Málaga 2P

Montagem dos Espelhos/Mirror Mounting /Ensamblaje de espejo.

Málaga Glass

Inicie a montagem posicionando os espelhos (22), entre os perfis junção, cantoneira e perfil puxador.
Logo fixe os espelhos (22), com parafusos (AF) e suporte vidro pino (AG).

Start the assembly by positioning the mirrors (22), between the joint profiles, corner and handle profile.
Then fix the mirrors (22), with screws (AF) and glass support pin (AG).

Comience el montaje colocando los espejos (22), entre los perfiles de unión, ángulo y tirador.
Luego fije los espejos (22), con los tornillos (AF) y el pasador de soporte del vidrio (AG).

Luego fije los espejos (22), con los tornillos (AF) y el pasador de soporte del vidrio (AG).



AF 8



Parafuso 3,5x14 CP 34125

AG 8



Suporte Vidro Pino 25678

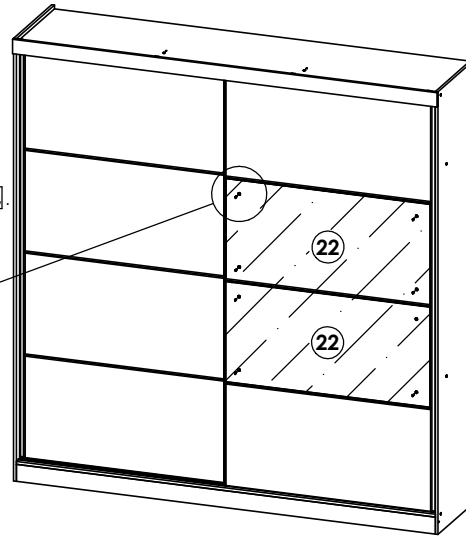
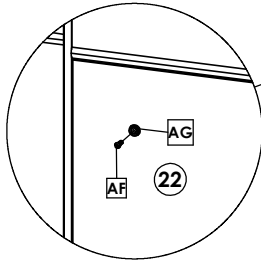

Montagem dos Espelhos/Mirror Mounting /Ensamblaje de espejo.

Málaga Full Glass

Inicie a montagem posicionando os espelhos (22), entre os perfis junção, cantoneira e perfil puxador.
Logo fixe os espelhos (22), com parafusos (AF) e suporte vidro pino (AG).

Start the assembly by positioning the mirrors (22), between the joint profiles, corner and handle profile.
Then fix the mirrors (22), with screws (AF) and glass support pin (AG).

Comience el montaje colocando los espejos (22), entre los perfiles de unión, ángulo y tirador.
Luego fije los espejos (22), con los tornillos (AF) y el pasador de soporte del vidrio (AG).

Luego fije los espejos (22), con los tornillos (AF) y el pasador de soporte del vidrio (AG).



AF 16



Parafuso 3,5x14 CP 34125

AG 16



Suporte Vidro Pino 25678

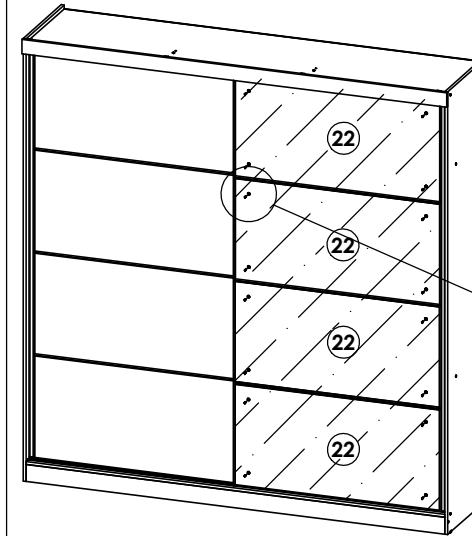
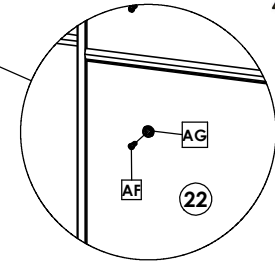

Produto Montado | Assembled Product | Producto montado

