

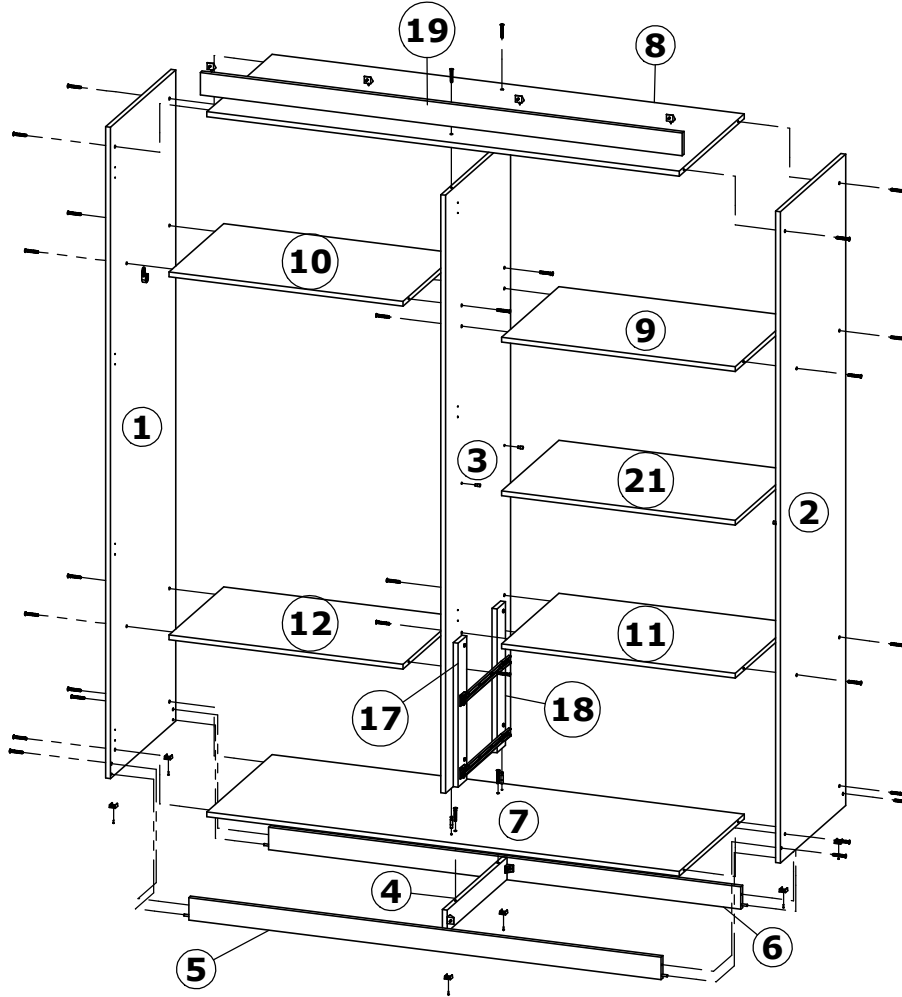

# Roupeiro Star 4P / Wardrobe Star 4P/ Ropero Star 4P

Faithful+Riddick



sexta-feira, 21 de fevereiro de 2025

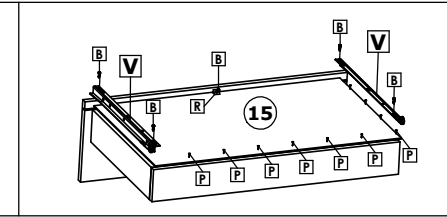
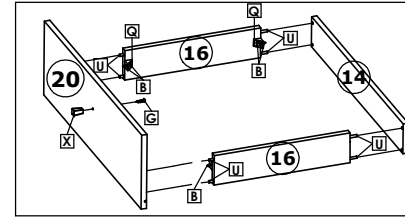

## Roupeiro Star 4P Branco

Peça Piece Pieza	Cod.	Descrição	Description	Descripción	Qtde Qty Cant	Compr Lenght Largo	Larg. Widht Ancho	Esp. Tickness Espesor
1	P20275	Lateral Esq.	Left Side Panel	Lateral Izquierda	1	2010	536	15
2	P20278	Lateral Dir.	Right Side Panel	Lateral Derecha	1	2002	536	15
3	P20276	Divisão	Division	División	1	1846	536	15
4	P13930	Divisão Pé	Division Foot	Pie división	1	492	68	15
5	P20280	Frente Pé	Frontal Botton Frame	Zocalo Frontal	1	1469	69,5	15
6	P20008	Traseiro Pé	Back Botton Frame	Zocalo Traseiro	1	1469	69,5	15
7	P20283	Tampo Inferior	Surface Bottom	Superficie inferior	1	1469	536	15
8	P20279	Tampo Superior	Table Top	Table Top	1	1469	536	15
9	P20005	Tampo Int. Maior	Top int. Bigger	Top Int. Más	1	727	472	15
10	P20004	Tampo Int. Menor	Top int. Smaller	Top Int. Menos	1	727	450	15
11	P20001	Tampo Gav. 1 ld s/ Pint.	Top drawer 1 s hand / Painting	Top Cajón s mano / Pintura	1	727	472	15
12	P20000	Tampo ( 1ld s/ Pint)	Top (1ld s / Pint)	Tapa (1ld s / Pint)	1	727	450	15
13	P19996	Fundo	Background	Fondo	2	1875	745	2,5
14	P20009	Traseiro Gaveta	Drawer Back	Traseiro Cajón	2	672	88	15
15	P17623	Fundo Gaveta	Drawer Back	Fondo Cajón	2	670	402	2,5
16	P15871	Lateral Gaveta	Drawer Side	Lateral Cajón	4	385	88	15
17	P17635	Distanciador	Spacer	Spacer	2	444	70	15
18	P15007	Distanciador s/ Pint.	Spacer s/ Pint.	Spacer s/ Pint.	2	444	70	15
19	P20282	Moldura Superior	Frame Superior	Enmarcar Superior	1	1499	70	15
20	P20273	Frente Gaveta	Drawer Front	Frente del Cajón	2	715	219	15
21	P20006	Prateleira	Shelf	Estante	1	727	472	15
22	P20272	Porta Menor	Door Smaller	Puerta Menos	2	1386	357	15
23	P20274	Porta Maior	Door Bigger	Puerta Más	2	1892	368	15

Cod. Qnt.

A   4	B   38	C   2	D   2	E   8	F   4	G   14	H   56	I   32
Parafuso 3,5x10 CC (P/Suporte Cabideiro) 36722	Parafuso 3,5x14 CP 25736	Parafuso Minifix 25679	Tambor Minifix 15x12,5 22388	Paraf. Correção 6x12 22396	Parafuso 3,0x10 CC 33199	Parafuso 3,5x25 CF 24648	Parafuso 4,0x14 CC 25673	Parafuso Soberbão 7x40 PH 10 25691
J   14	K   8	L   6	M   2	N   20	O   19	P   123	Q   14	R   2
Calço p/ Dobradça 23273	Dobradça Baixa 23271	Dobradça Alta 23272	Suporte Cabideiro 36611	Tampa Soberbão 27089 - Branco	Presilha Fundo 24099	Prego 10x10 CC 20179	Cantoneira 20x20x20 37090	Suporte Triangular 30094
S   2	T   4	U   20	V   2	W   2	X   6	Y   1	Z   1	AA   1
Tampa Tambor 36012 - Cinza Social	Suporte Prateleira 36013 - Cinza Social	Cavilha 6x30 24603	Kit Correção 400mm 21611	Tampa Furo 5mm 36009 - Cinza Social	Puxador Ponto Bronze 34842	Cab. Oblongo 719mm 36929	Sachê de Cola 25676	Adesivo Logotipo THB 31363
AB   6	AC   1	-	-	-	-	-	-	-
Sapata Plástica U 25677 - Branco	Gabarito de Cabideiro 36919							

## Roupeiro Star 4P Branco Glass

24	38943	Espelho	Mirror	Espejo	2	1000	290	3
----	-------	---------	--------	--------	---	------	-----	---



**Atenção com a cor do acabamento!  
Em caso de assistência solicitar o código  
de acordo com a cor da peça.**

Medidas em mm



m.motta

# Roupeiro Star 4P / Wardrobe Star 4P/ Ropero Star 4P

## 1º Passo / Step / Paso

Fixar divisão pé ④ no tampo inferior ⑦ com parafusos soberbão ①. Logo fixar com cantoneira ② e parafuso ③ a frente e traseiro pé ⑤ e ⑥ nas divisões pé ④.

Fix foot division ④ on the lower top ⑦ with screws ①. Then fix with angle iron ② and screw ③ at the front and rear foot ⑤ and ⑥ in the foot ④ divisions.

Fije la división de pies ④ en la parte superior inferior ⑦ con tornillos ①. Luego fíjelo con un ángulo de hierro ② y atornille ③ en la parte delantera y trasera del pie ⑤ y ⑥ en las divisiones del pie ④.

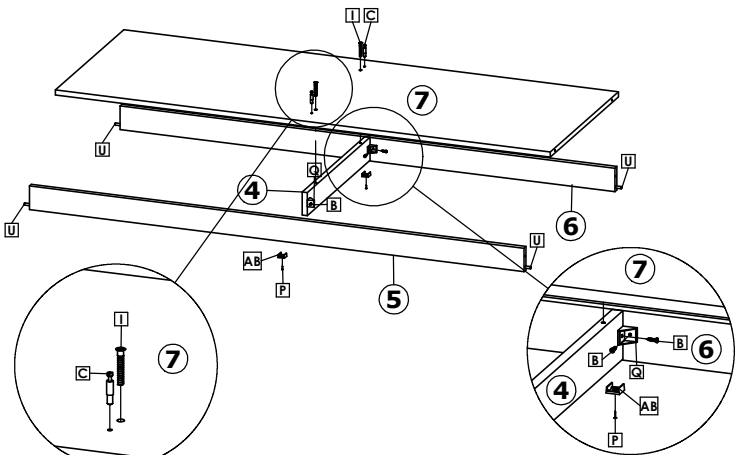

## 2º Passo / Step / Paso

Fixar laterais ①, ② e divisão ③ no tampo inferior ⑦, com parafusos ①, ③ e tambor ④.

Em seguida fixar tamos ⑨, ⑩, ⑪ e ⑫, com parafusos ①.

Fix sides ①, ② and division ③ to the lower top ⑦, with screws ①, ③ and drum ④. Then attach tops ⑨, ⑩, ⑪ and ⑫, with screws ①.

Fije los lados ①, ② y la división ③ a la parte superior inferior ⑦, con los tornillos ①, ③ y el tambor ④. Luego fije las tapas ⑨, ⑩, ⑪ y ⑫, con los tornillos ①.

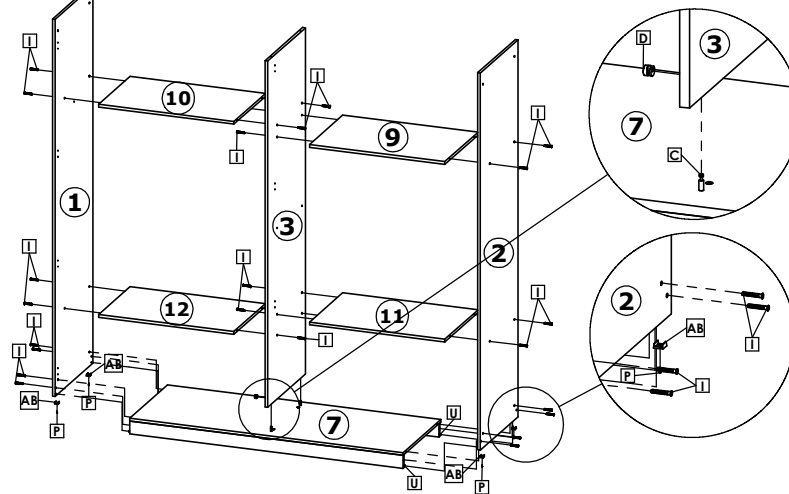

## 3º Passo / Step / Paso

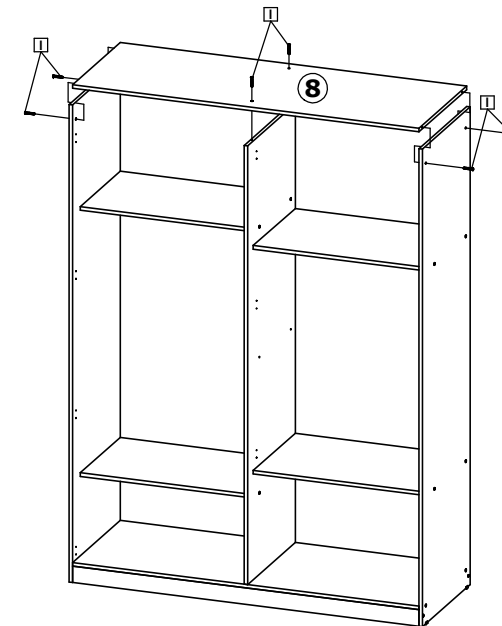

## 4º Passo / Step / Paso

Fixar Fundos ⑬, com Pregos ② e Presilhas ④.

Attach Funds ⑬, with Nails ② and Clips ④.

Fijar Fondos ⑬, con clavos ② y sujetadores ④.

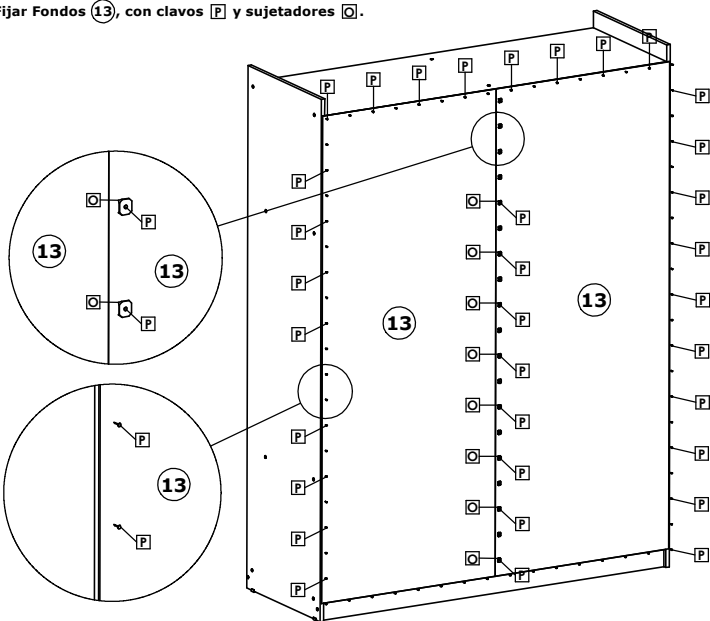

## 5º Passo / Step / Paso

Fixar as molduras ⑲ com cantoneira ② e parafusos ③.

Fix the frames ⑲ with angle bracket ② and screws ③.

Fix the frames ⑲ with angle bracket ② and screws ③.

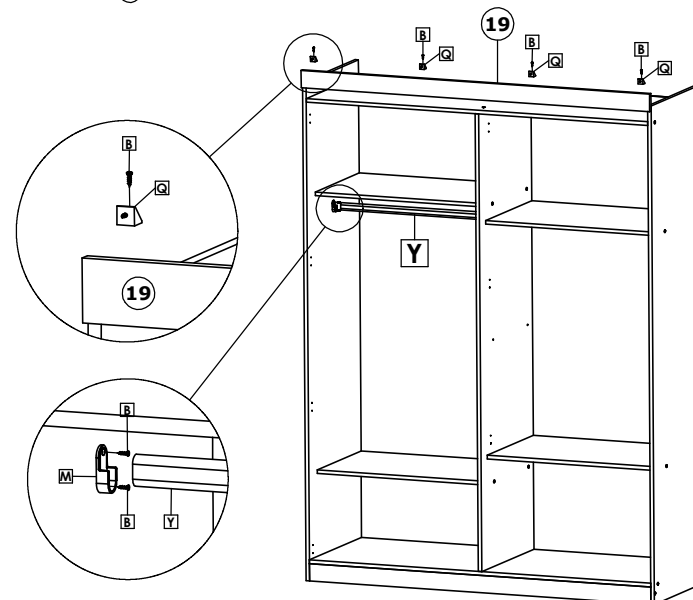

## 6º Passo / Step / Paso

Posicionar o Distanciador ⑰ paralelo ao Tampo ⑪.

Position Spacer ⑰ parallel to Top ⑪.

Posicionar el Distanciador ⑰ paralelo al Tablero ⑪.

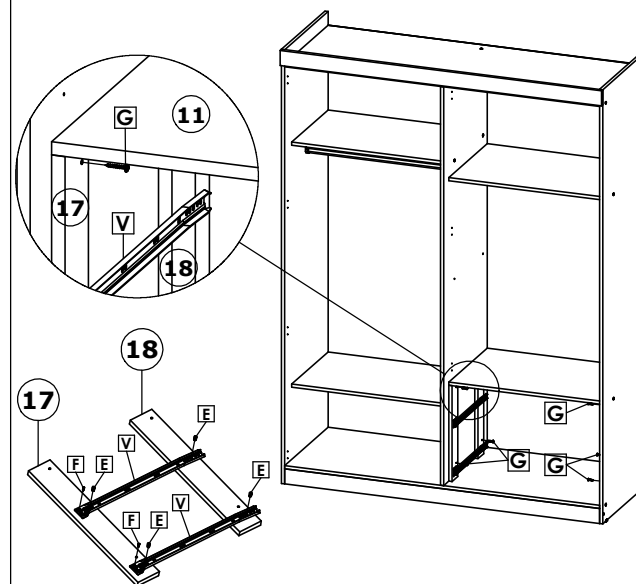

# Roupeiro Star 4P / Wardrobe Star 4P/ Ropero Star 4P

## 7º Passo / Step / Paso

Faça o encaixe dos Suportes de Prateleiras e das Gavetas, conforme ilustrado abaixo.  
 Attach the Shelf Brackets and Drawers, as shown below.  
 Haga el acoplamiento de los soportes de estantes y de los cajones, como se muestra a continuación.

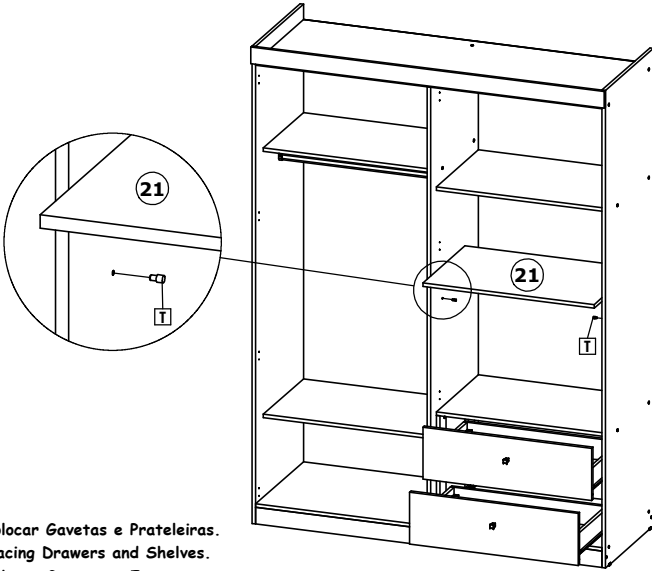



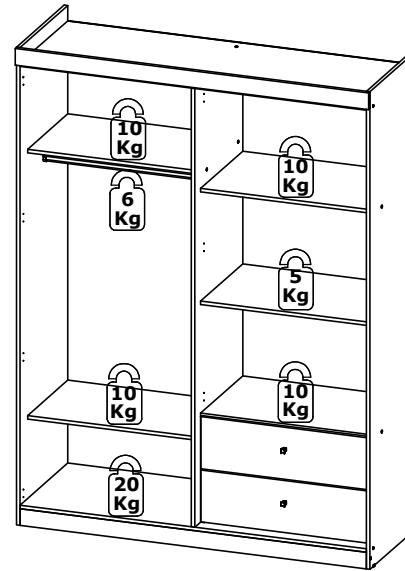

Colocar Gavetas e Prateleiras.  
 Placing Drawers and Shelves.  
 Colocar Gavetas y Estantes.





## Peso Suportado / Weight supported / peso que soporta







Peso Suportado por cada gaveta.  
 Weight Supported per drawer.  
 Peso soportado por cada cajón.  5 Kg





## Montagem das Portas / Mounting the Doors/ Montaje de las Puertas



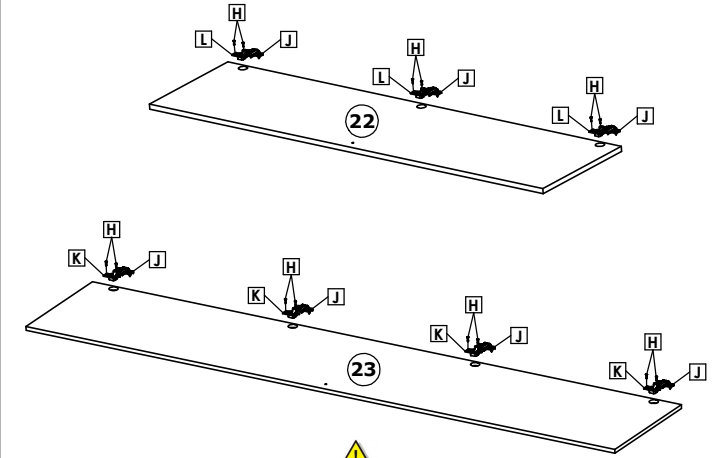

 Usar dobradiça alta , calço  e parafuso  nas portas .





Use high hinge , wedge  and screw  on doors .

Utilice la bisagra alta , la cuña  y el tornillo  en las puertas .







 Usar dobradiça baixa , calço  e parafuso  nas portas .

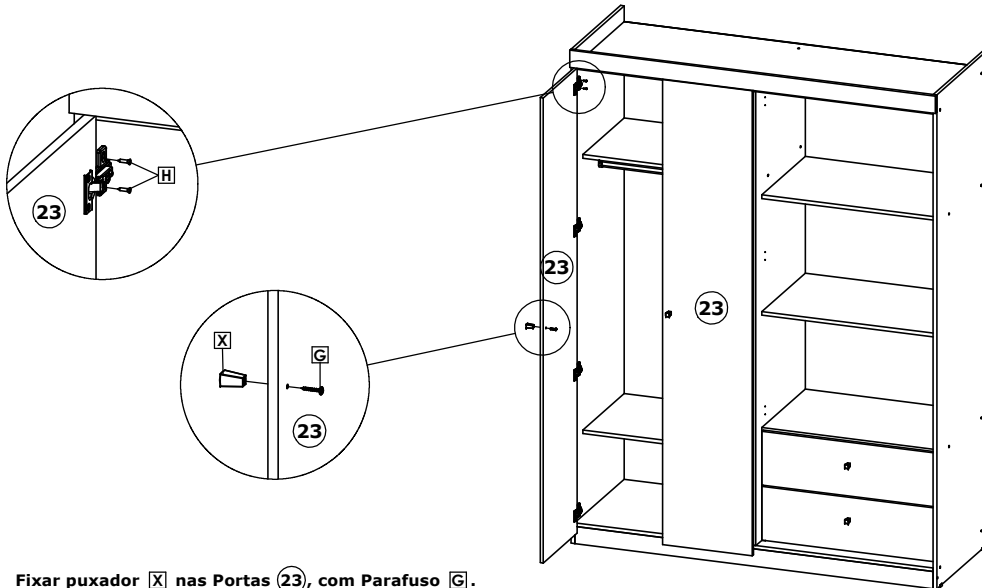

Use low hinge , wedge  and screw  on doors .



Utilice la bisagra baja , la cuña  y el tornillo  en las puertas .

## 8º Passo / Step / Paso





Fixar puxador  nas Portas , com Parafuso .

Attach knob  on doors , with screw .

Fijación tirador  en las puertas , con tornillo .

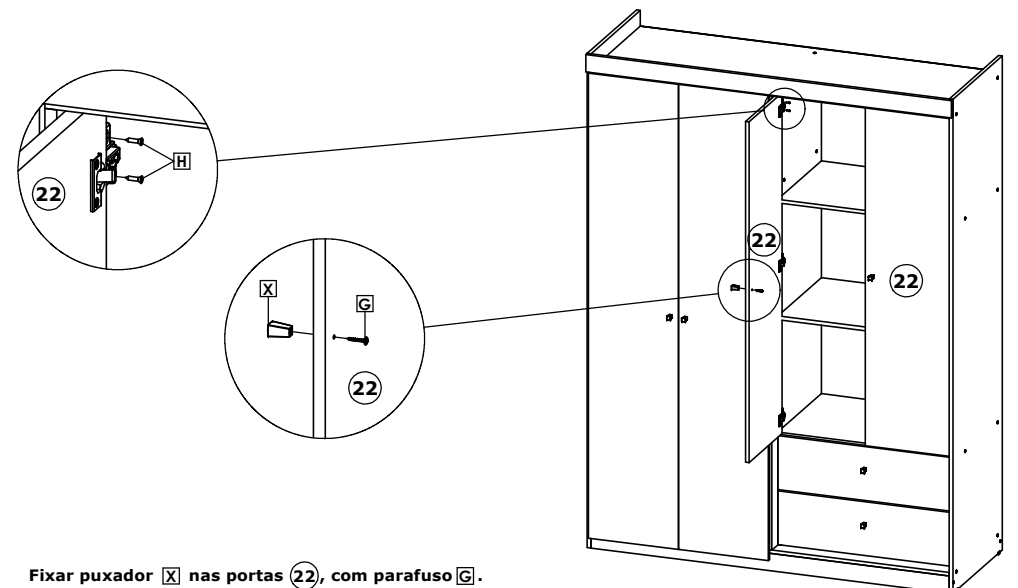
## 9º Passo / Step / Paso



Fixar puxador  nas portas , com parafuso .

Attach Knob  on Doors , with Screw .

Fijación Tirador  en las Puertas , con Tornillo .

# Roupeiro Star 4P / Wardrobe Star 4P/ Ropero Star 4P

10º Passo / Step / Paso

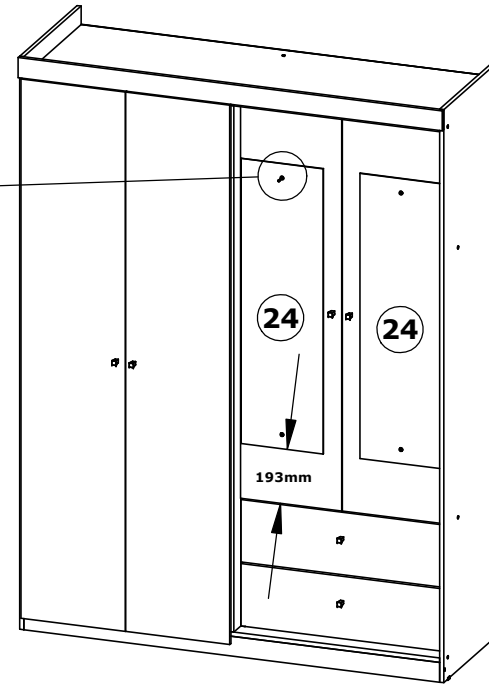
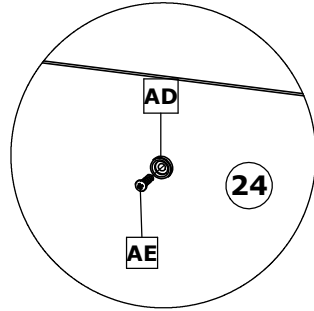

Alinha os espelhos a borda da porta pelo lado da dobradiça, deixando o espelho centralizado na altura da porta com uma folga de 193mm .  
Em seguida fixar os espelhos (24) com parafusos (AE) e suporte vidro pino (AD).

Align the mirrors with the edge of the door on the hinge side, leaving the mirror centered at the height of the door with a gap of 193 mm.  
Then fix the mirrors (24) with screws (AE) and glass support pin (AD).

Alinee los espejos con el borde de la puerta en el lado de las bisagras, dejando el espejo centrado en el altura de la puerta con un espacio libre de 193 mm.

A continuación, fije los espejos (24) con los tornillos (AE) y pasador de soporte de vidrio (AD).

AD 4



Suporte Vidro Pino  
25678

AE 4



Parafuso 3,5x14 CP  
34125

Produto Montado | Assembled Product | Producto ensamblado

## Star 4P

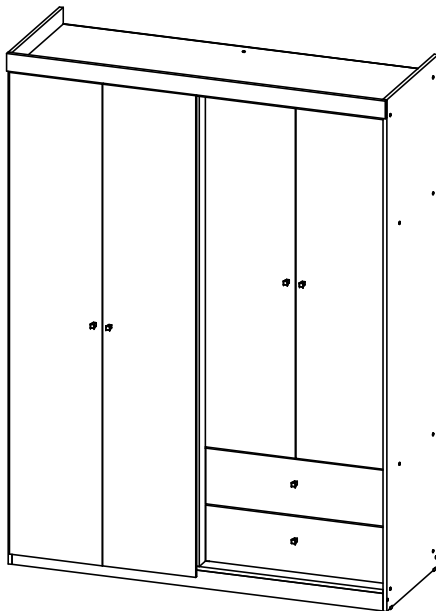

## Star 4P Glass

