

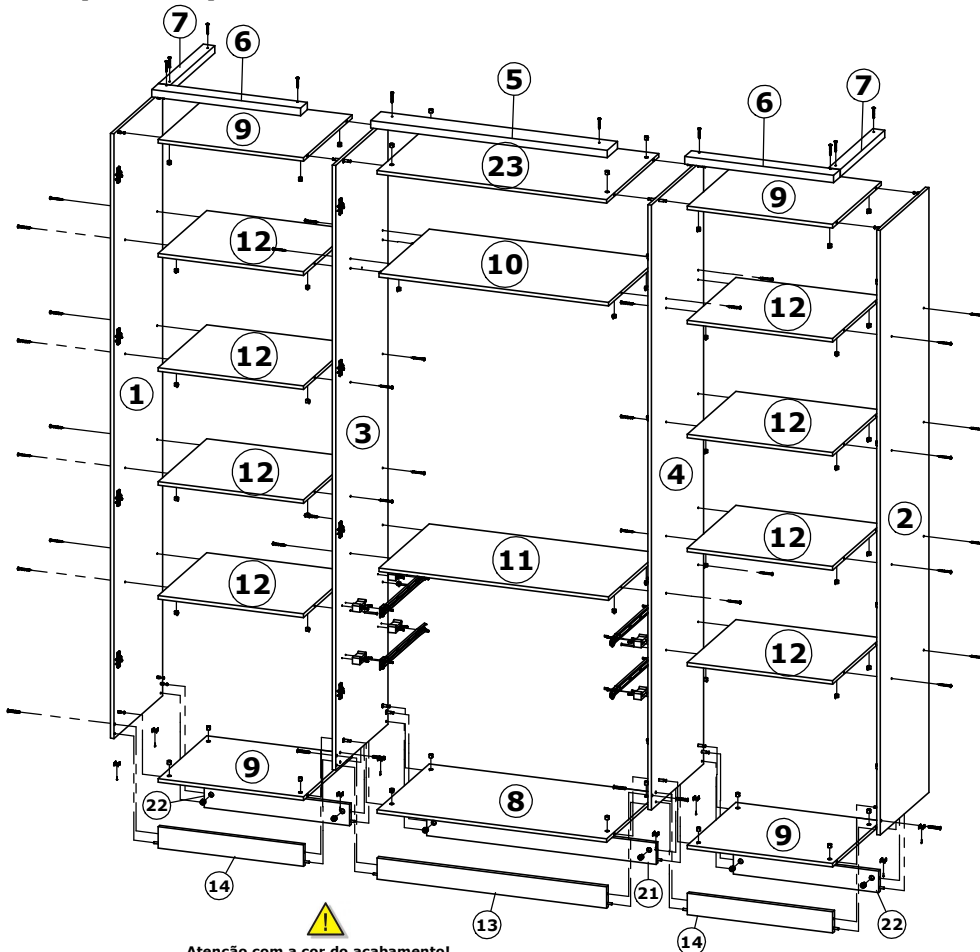

Roupeiro Splendore 4 Portas / Wardrobe Splendore 4 Doors / Ropero Splendore 4 Puertas

Roupeiro Splendore Nogal c/ Linho

sexta-feira, 8 de agosto de 2025



| Peça Pieze Pieza | Nogal | Descrição | Description | Descripción | Qtde Qty Cant | Compr Length Largo | Larg. Width Ancho | Esp. Thickness Espesor |
|------------------------|--------|-----------------------|------------------------|------------------------|---------------------|--------------------------|-------------------------|------------------------------|
| 1 | P20548 | Lateral Esquerda | Left Panel | Lateral Izquierda | 1 | 2036 | 436 | 12 |
| 2 | P20550 | Lateral Direita | Right Panel | Lateral Derecha | 1 | 2036 | 436 | 12 |
| 3 | P20542 | Divisão Esquerda | Left Division | Division Izquierda | 1 | 2036 | 468 | 12 |
| 4 | P20547 | Divisão Direita | Right Division | Division Derecha | 1 | 2036 | 468 | 12 |
| 5 | P20544 | Moldura Sup. Central | Central Beam Frame | Marco suprimido | 1 | 803 | 92 | 25 |
| 6 | P20546 | Moldura Sup. Menor | Smallest Sup. Frame | Marco Sup. Menor | 2 | 505 | 60 | 25 |
| 7 | P20545 | Moldura Sup. Lateral | Side Superstructure | Lámpara Sup. Lateral | 2 | 401 | 30 | 25 |
| 8 | P16390 | Tampo Inf Central | Top Inf Central | Tapa Inf Central | 1 | 779 | 468 | 12 |
| 9 | P16387 | Tampo Sup/Inf Lat. | Sup / Inf Lateral Top | Tapa Sup / Inf Lateral | 4 | 493 | 436 | 12 |
| 10 | P16384 | Tampo Intermediário | Intermediate Top | Tapa | 1 | 779 | 450 | 12 |
| 11 | P16383 | Tampo (1ld s/Pintura) | Cover (One ld painted) | Tapa (1ld s/ pintura) | 1 | 779 | 450 | 12 |
| 12 | P16388 | Tampo Lateral | Lateral Top | Tapa lateral | 8 | 493 | 436 | 12 |
| 13 | P20543 | Frente Pé Central | Front Center Foot | Frente Pie Central | 1 | 779 | 72 | 15 |
| 14 | P20549 | Frente Pé Lateral | Front Side Foot | Del lado derecho | 2 | 493 | 72 | 15 |
| 15 | P16392 | Frente Gaveta | Drawer Frontal | Frente del Cajón | 2 | 723 | 149 | 12 |
| 16 | P16060 | Lateral Gaveta | Side Drawer | Lateral del Cajón | 4 | 385 | 88 | 12 |
| 17 | P16393 | Fundo Gaveta | Bottom Drawer | Fondo del Cajón | 2 | 704 | 403 | 2,5 |
| 18 | P16391 | Traseiro Gaveta | Rear Drawer | Traseo del Cajón | 2 | 704 | 88 | 12 |
| 19 | P16381 | Fundo Central | Central Fund | Fondo Central | 2 | 1964 | 392 | 2,5 |
| 20 | P16382 | Fundo Lateral | Lateral Background | Fondo Lateral | 4 | 1964 | 249 | 2,5 |
| 21 | P14731 | Traseiro Pé Central | Rear Center Foot | Trasero Pie Central | 1 | 779 | 72 | 15 |
| 22 | P14728 | Traseiro Pé Lateral | Rear Foot | Trasero Pie Lateral | 2 | 493 | 72 | 15 |
| 23 | P17543 | Tampo Sup Central | Top Sup Central | Tapa Sup Central | 1 | 779 | 468 | 12 |
| 24 | P20540 | Porta Lateral | Side Door | Puerta Lateral | 2 | 1952 | 495 | 15 |
| 25 | P20541 | Porta Central | Central Door | Puerta Central | 2 | 1952 | 394 | 15 |



Atenção com a cor do acabamento!
Em caso de assistência solicitar o código de acordo com a cor da peça /
Pay attention to the color of the finish!
In case of assistance request the code according to the color of the part /
Atención con el color del acabado!
In case of asistencia solicitar el código de acuerdo con el color de la pieza.

Cod. Qnt.

| | | | | | | | | |
|------------------------------------|--|---|---|---|--|---|--|--|
| A 10 Parafuso Bigfix 33160 | B 24 Parafuso 3,5x12 CP 33297 | C 2 Puxador Ponto Canaan 34842 - Bronze | D 6 Parafuso Soberbão 7x40 25691 | E 76 Parafuso 4,0x12 CC 30189 | F 36 Parafuso 4,0x50 CF 33292 - Zincado Amarelo | G 4 Parafuso 4,0x50 CC 33696 - Zincado Amarelo | H 28 Cavilha 6x30 24603 | I 2 Parafuso 3,5x25 CF 24648 (Puxador Ponto Canaan) |
| J 10 Parafuso 4,0x35 CF 29815 | K 4 Parafuso 3,5x10 CC 36722 (Emb. c/ Sup. Cabideiro) | L 4 Parafuso 3,5x30 CF 25700 (Puxador Citrino) | M 18 Parafuso 3,5x14 CP 34125 - Zincado Branco | N 10 Paraf. Minifix Haste Dupla 30198 | O 40 Presilha Fundo 24099 | P 150 Prego 10x10 20179 | Q 8 Sapata Plástica 12x12 40360 - Nogal | R 2 Sache de cola 10g 25676 |
| S 6 Tambor Minifix 15mm 22388 | T 24 Tambor Minifix 12mm 30182 | U 24 Tampa Tambor Minifix 36012 - Linho | V 4 Tampa Soberbão 40257 - Nogal | W 2 Suporte Triângular 30094 | X 40 Porca Cilíndrica 36008 - Linho | Y 8 Cantoneira Plástica 36010 - Linho | Z 16 Calço p/ Dobradça 23273 | AA 16 Dobradça Baixa 23271 |
| AB 2 Suporte Cabideiro 36611 | AC 1 Adesivo Logotipo THB 31363 | AD 2 Corredor 400mm 21611 | AE 2 Distanciador 25mm 37492 | AF 2 Puxador Less 512mm 37847 - Bronze 39323 - Ponteira Bronze | AG 2 Perfil H 1964mm 36904 - Linho | AH 1 Cab. Oblongo 772mm 35138 | | |

Espejos Splendore Plus Glass

| | | | | | | | | |
|----|-------|---------------|------------------|--------------|---|-----|-----|---|
| 26 | 34801 | Espelho Maior | DoorLarge Mirror | Espejo Mayor | 2 | 974 | 350 | 3 |
| 27 | 34802 | Espelho Menor | Small Mirror | Espejo Menor | 4 | 487 | 350 | 3 |

Espejos Splendore Glass

| | | | | | | | | |
|----|-------|---------------|------------------|--------------|---|------|-----|---|
| 27 | 30919 | Espelho Maior | DoorLarge Mirror | Espejo Mayor | 2 | 1348 | 350 | 3 |
|----|-------|---------------|------------------|--------------|---|------|-----|---|

Ferramentas necessárias (Não fornecidas)
Tools Required (Not Provided)
Herramientas necesarias (no incluidas)



Medidas em mm



m.motta

Roupeiro Splendore 4 Portas / Wardrobe Splendore 4 Doors / Ropero Splendore 4 Puertas

1º Passo / Step / Paso

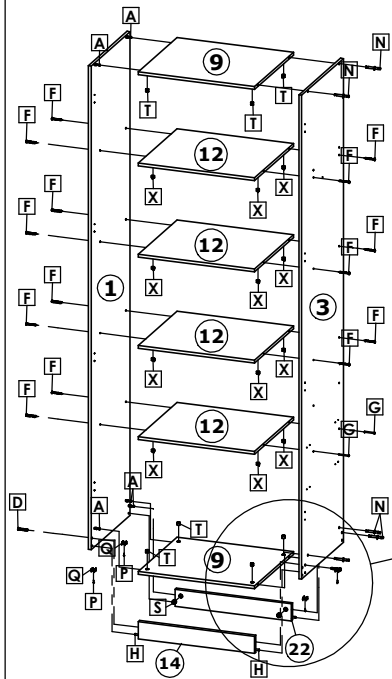

Inicie a Montagem pelas Torres Laterais, fixando Laterais ① e ②, Divisões ③ e ④, nos Tornos ⑨ e ⑫, com Parafusos F, D, N e A/

Start the Assembly by the Side Towers, fixing Side ① and ②, Divisions ③ and ④, on Tops ⑨ and ⑫, with Screws F, D, N and A/

Inicie el Montaje por las Torres Laterales, fijando Laterales ① y ②, Divisiones ③ y ④, en los Tableros ⑨ y ⑫, con Tornillos F, D, N y A.

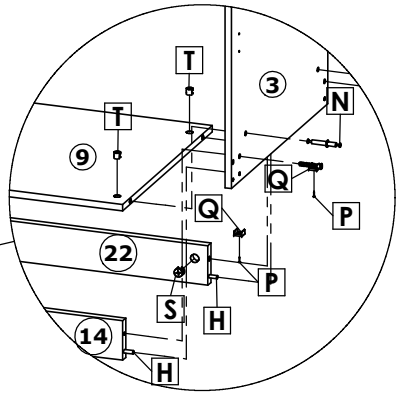

2º Passo / Step / Paso

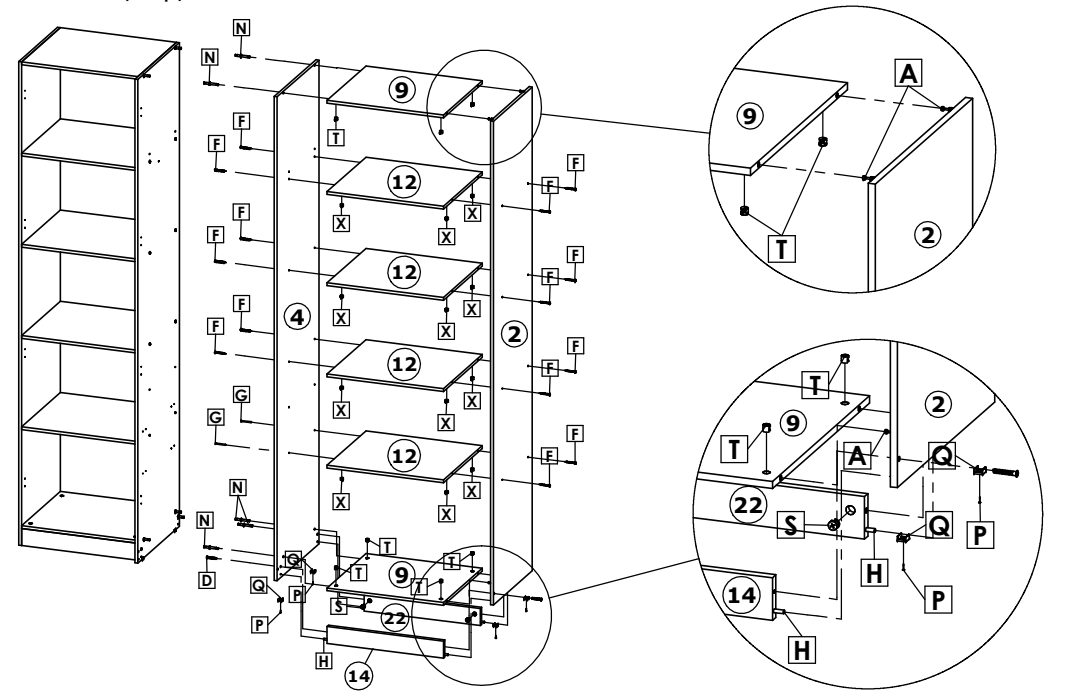

3º Passo / Step / Paso

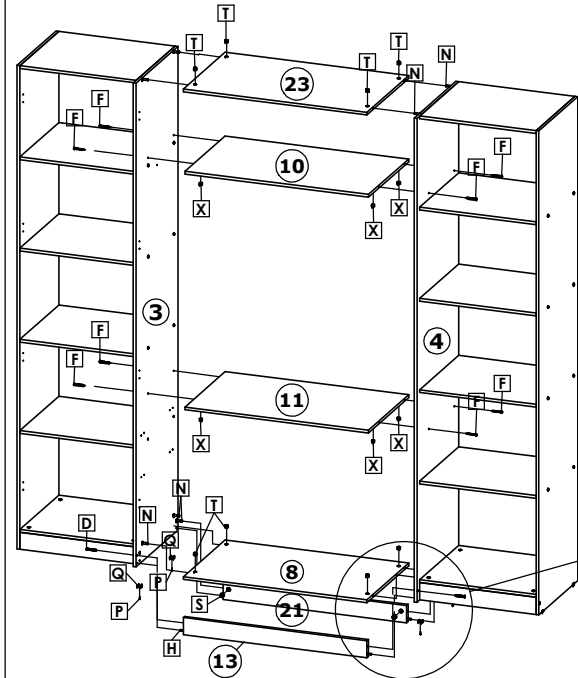

Após a montagem das duas Torres Laterais, fixar os tornos Centrais (23, 8, 10 e 11) com Parafusos N, F e Tambor T. Já a Frente Pé (13) e Traseiro Pé (21), fixar com Parafusos D, N e Tambor S/

After the assembly of the two Side Towers, fix the Central tops (23, 8, 10 and 11) with Screws N, F and Drum T. Already the Front Foot (13) and Rear Foot (21), fix with Screws D, N and Drum S/

Después del montaje de las dos Torres Laterales, fijar las encimeras Centrales (23, 8, 10 y 11) con Tornillos N, F y Tambor T. En la parte frontal del pie (13) y trasero pie (21), fijar con tornillos D, N y tambor S.

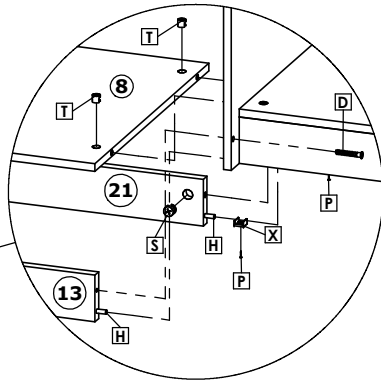

4º Passo / Step / Paso

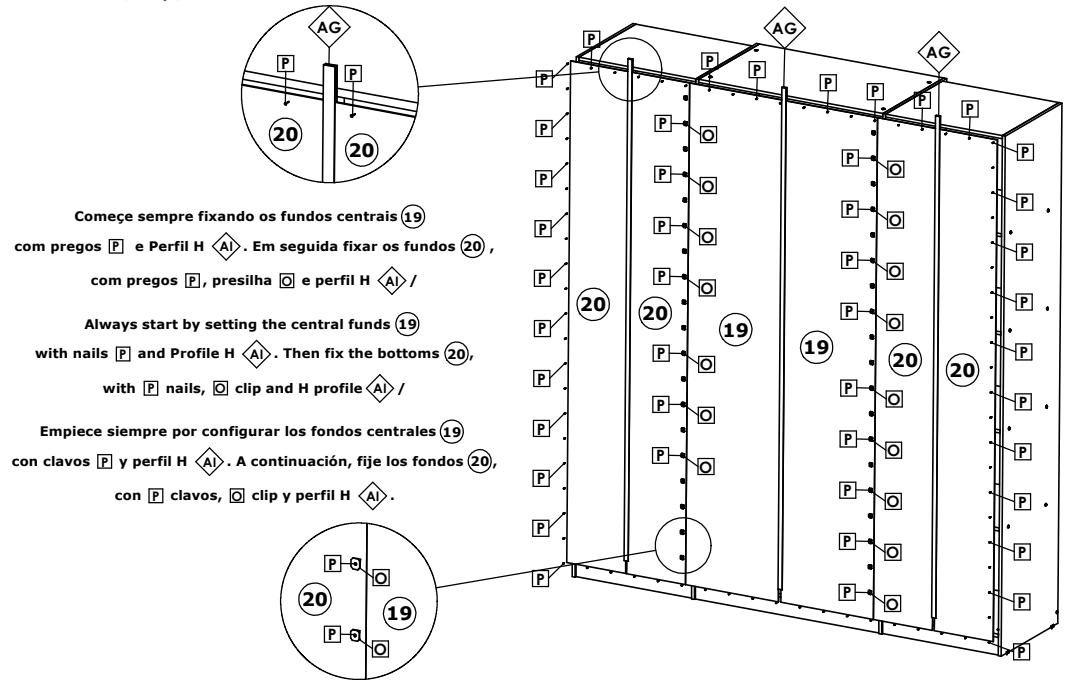

Comece sempre fixando os fundos centrais (19) com pregos P e Perfil H (A). Em seguida fixar os fundos (20), com pregos P, presilha Q e perfil H (A) /

Always start by setting the central funds (19) with nails P and Profile H (A). Then fix the bottoms (20), with P nails, Q clip and H profile (A) /

Espiece siempre por configurar los fondos centrales (19) con clavos P y perfil H (A). A continuación, fije los fondos (20), con P clavos, Q clip y perfil H (A).

Roupeiro Splendore 4 Portas / Wardrobe Splendore 4 Doors / Ropero Splendore 4 Puertas

5º Passo / Step / Paso

Após posicionar as Molduras Superior ⑤, ⑥ e ⑦, fixa-las com Parafuso J /
 After positioning the Top Frames ⑤, ⑥ and ⑦, secure them with Screw J /
 Después de colocar los Marcos Superior ⑤, ⑥ y ⑦, fijarlos con Tornillo J.

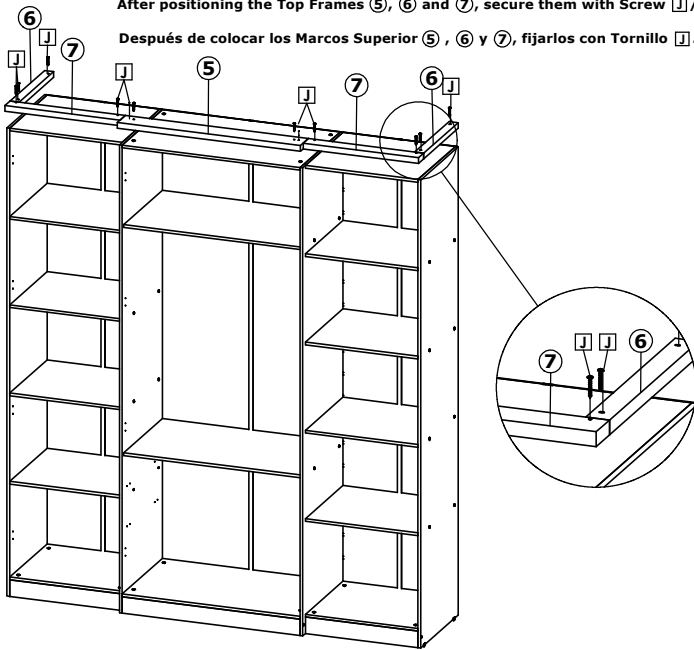

6º Passo / Step / Paso

Montagem das Gavetas / Mounting the Drawers / Montaje del Cajón.

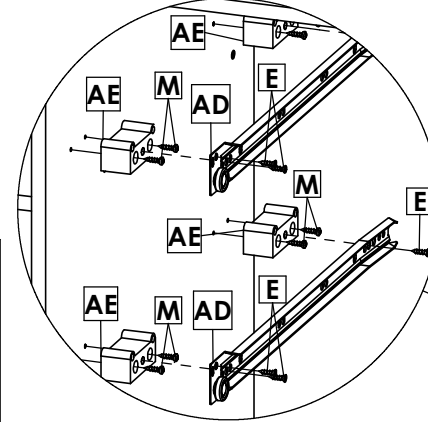
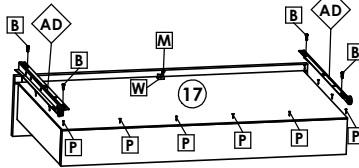
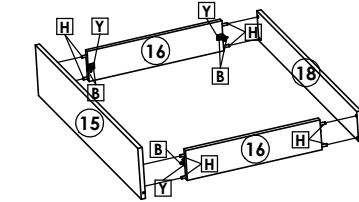

Fixar os distanciadores AE nas divisões ③ e ④, com parafusos M.
 Logo fixar as correijas AD e AD nos distanciadores AE com parafusos E /
 Fix spacers AE in divisions ③ and ④, with screws M.
 Then fix the slides AD and AD on the spacers AE with screws E /
 Fije los espaciadores AE en las divisiones ③ y ④, con tornillos M.
 Luego fije las diapositivas AD y AD en los espaciadores AE con tornillos E.

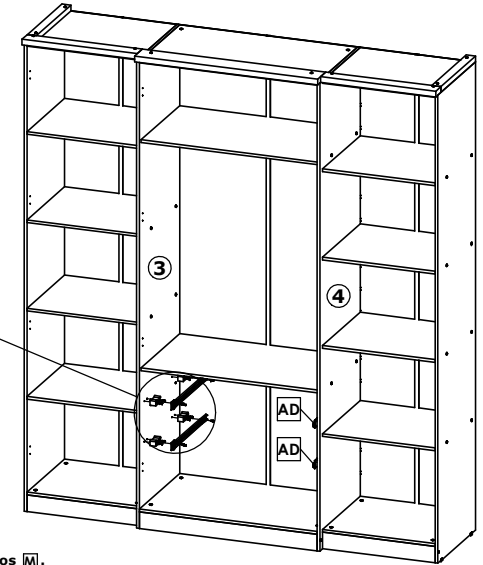

7º Passo / Step / Paso

Peso Suportado / Weight supported / peso que soporta



Fixar Suportes de Cabideiro AB, com Parafuso K nas Divisões ③ e ④ /
 Attach Clothes Rack AB with Screw K in Divisions ③ and ④ /
 Fijar Soportes de Cabelzal AB, con Tornillo K en las Divisiones ③ y ④.

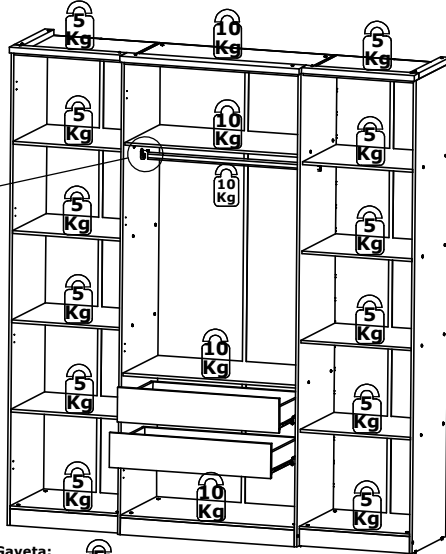
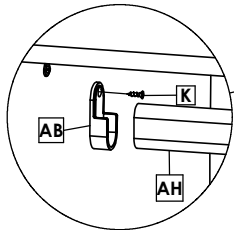

Peso suportado po cada Gaveta:
 Weight supported by each Drawer:
 Peso suportado por cada Cajón: 5 Kg

Montagem Portas Splendore / Splendore Doors / Puertas Splendore

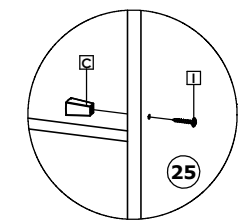
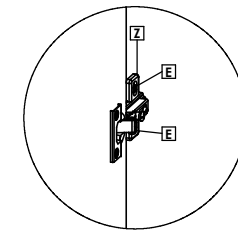
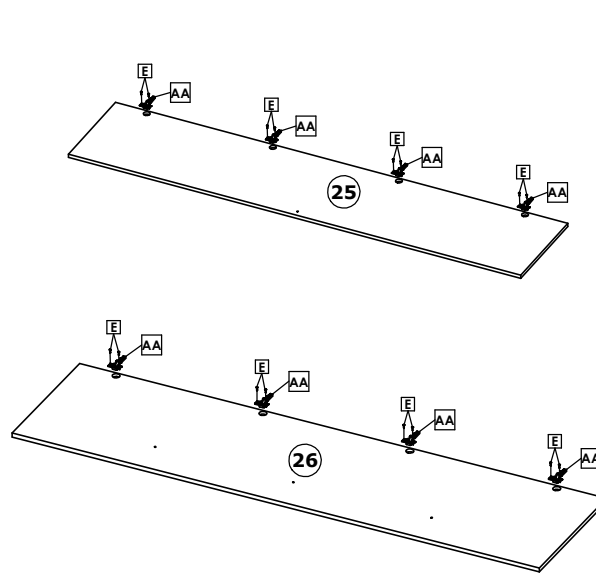

Fixar Puxador C, com Parafuso I /
 Attach Knob C, with Screw I /
 Fijación Tirador C, con Tornillo I.

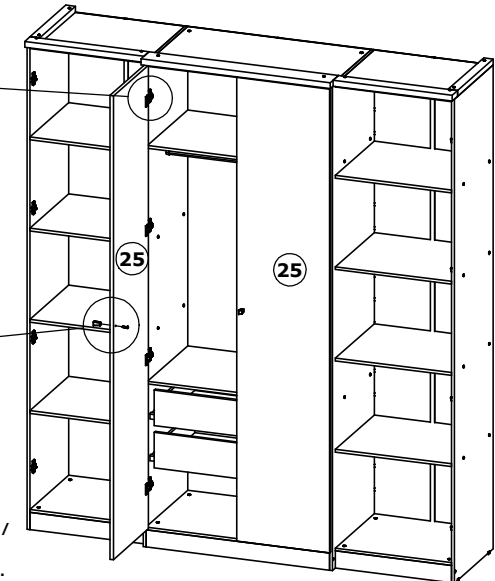

Roupeiro Splendore 4 Portas / Wardrobe Splendore 4 Doors / Ropero Splendore 4 Puertas

Montagem Portas Splendore/ Splendore Doors / Puertas Splendore

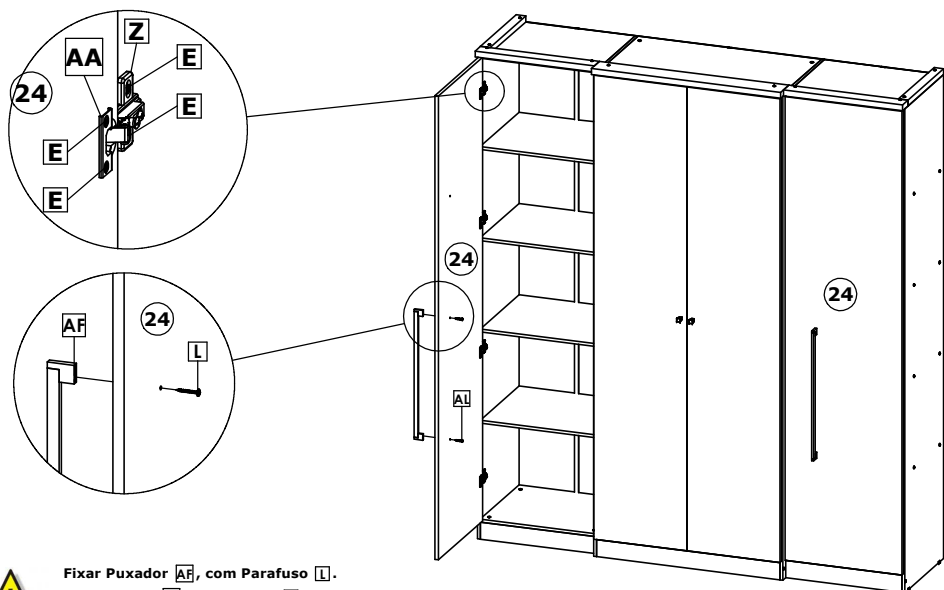

Fixar Puxador AF, com Parafuso L.
 Attach Knob AF, with Screw L.
 Fijación Tirador AF, con Tornillo L.

Inicie a montagem alinhando os Espelhos Superior (27), com a Lateral e topo da Porta (25).
 Logo inserir os Espelhos (26) e (27), fixando-os com Parafusos AJ e Suporte Vidro Pino AI, deixando entre cada Espelho um espaçamento de 2mm/
 Start the assembly by aligning the Top (27), Mirrors with the Side and Top of Door (25).
 Then insert Mirrors (26) and (27), securing them with Screws AJ and Glass Pin Support AI, leaving between each Mirror a spacing of 2mm/
 Inicie el montaje alineando los espejos (27) superior, con el lateral y la parte superior de la puerta (25).
 Luego inserte los Espejos (26) y (27), fijándolos con Tornillos AJ y Soporte Vidrio Pino AI, dejando entre cada espejo un espaciamento de 2mm.

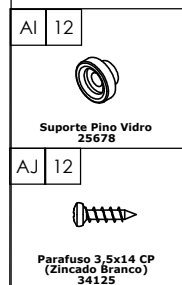
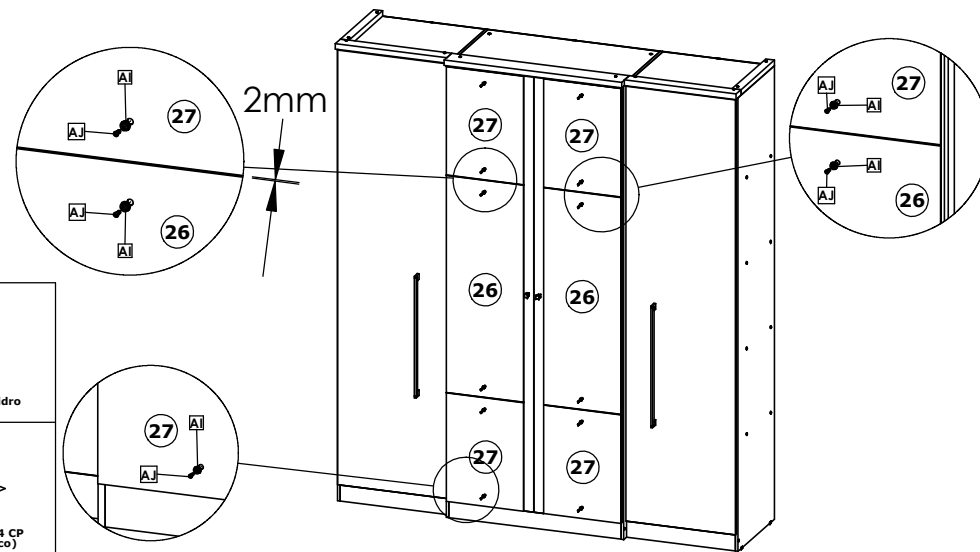

Posicione os Espelhos (26), á 302mm do Topo da Porta (25) e paralelo a lateral da Porta (25).

Logo fixe os Espelhos (26), com Parafusos AN e Suporte Vidro Pino AM /

Position Mirrors (26), 302mm from Top of Door (25) and parallel to side of Door (25).

Then secure the Mirrors (26), with Screws AN and Mount Glass Pin AM /

Coloque los espejos (26), a 302mm de la parte superior de la puerta (25) y paralelo al lateral de la puerta (25).

Luego fije los Espejos (26), con Tornillos AN y Soporte Vidrio Pino AM.

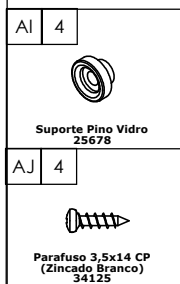
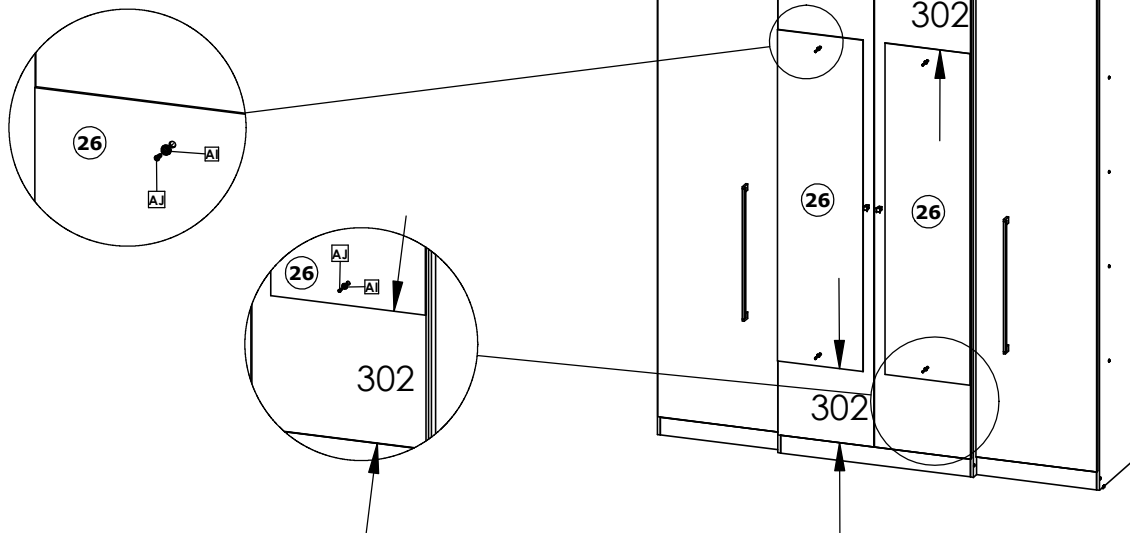

Splendore

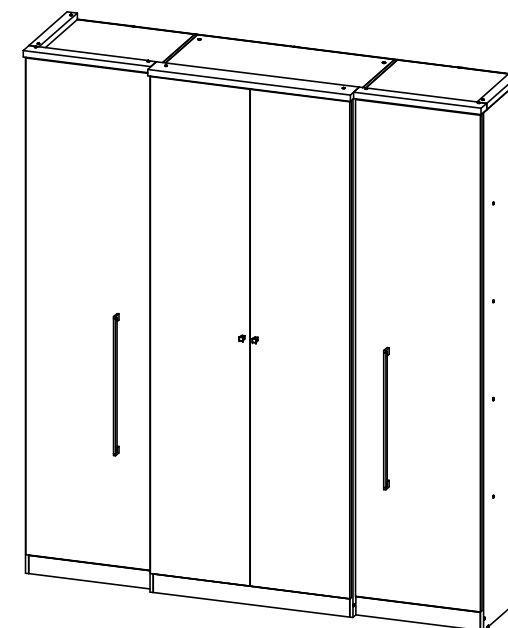

Roupeiro Splendore 4 Portas / Wardrobe Splendore 4 Doors / Ropero Splendore 4 Puertas

Splendore Glass

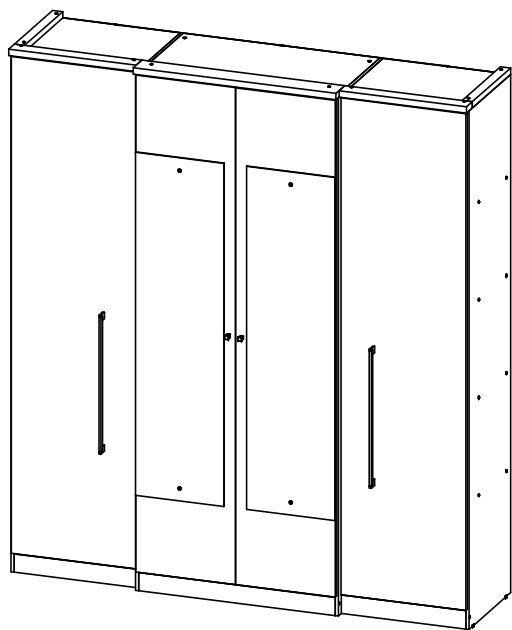

Splendore

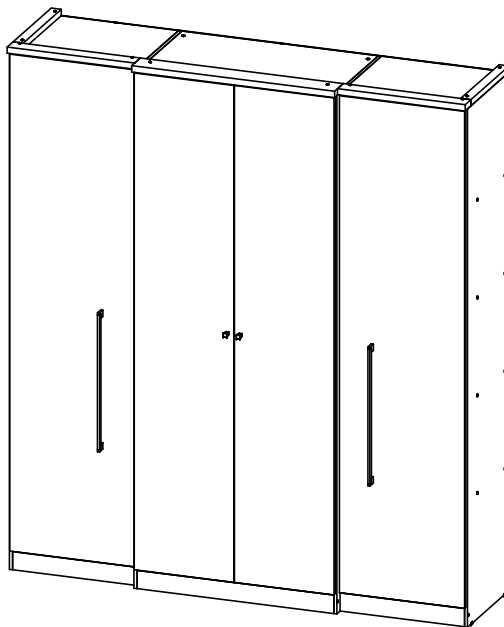

Splendore Plus Glass

