

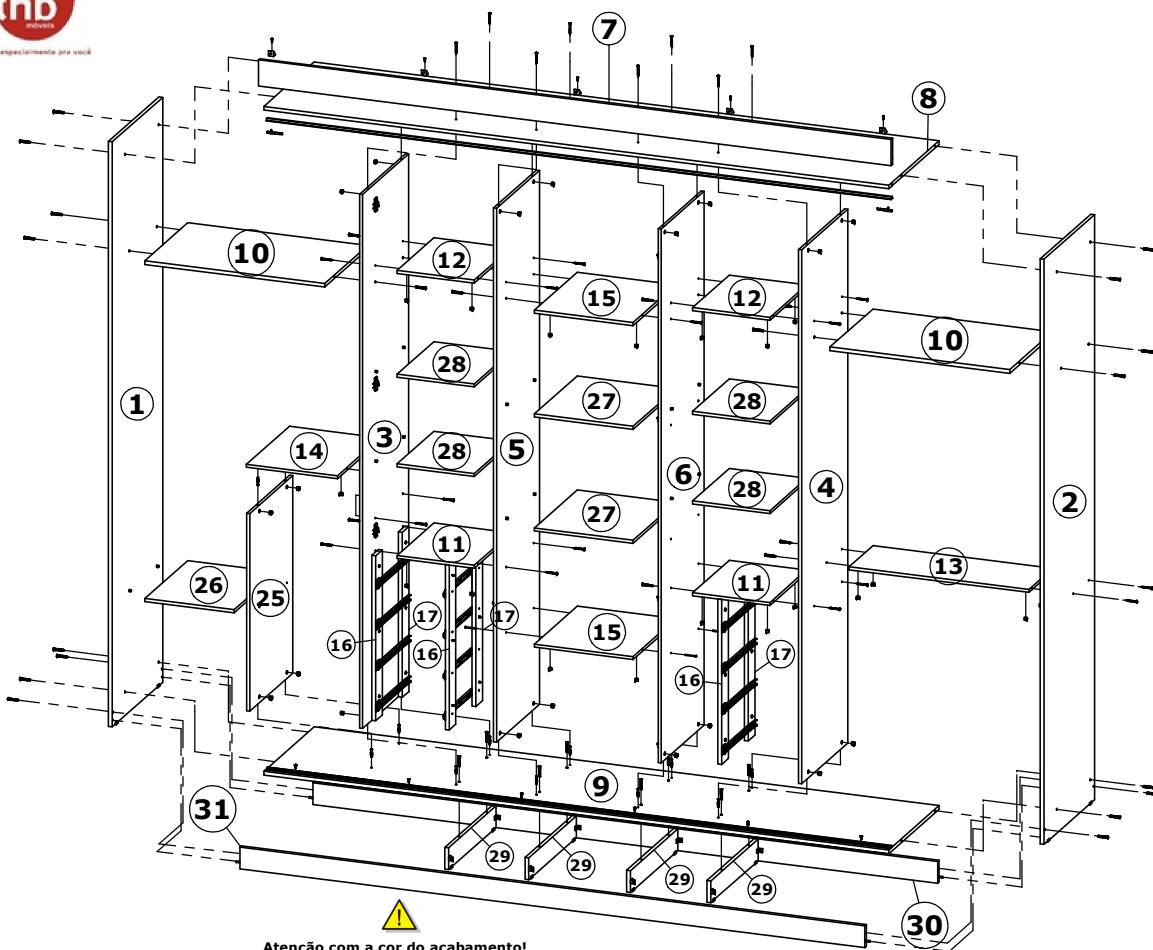

Roupeiro Sognare Glass 5 Portas / Wardrobe Sognare Glass 5 Doors / Ropero Sognare Glass 5 Puertas

quarta-feira, 21 de dezembro de 2022



Roupeiro Sognare Carvalho Sensitive C| Linho

Peça / Piece	Cod.	Descrição	Description	Descripción	Qtde / Qty	Compr / Lengh Largo	Larg. / Widht Ancho	Larg. / Lengh Largo	/Material Material
1	P14658	Lateral Esquerda	Left Panel	Lateral Izquierda	1	2298	528	15	MDP
2	P14657	Lateral Direita	Right Panel	Lateral Derecha	1	2298	528	12	MDP
3	P16361	Divisão Esquerda	Left Division	Division Izquierda	1	2097	482	12	MDP
4	P16367	Divisão Direita	Right Division	Division Derecha	1	2097	482	12	MDP
5	P16363	Divisão Central Esq.	Central Division Esq.	División Central Esq.	1	2097	450	12	MDP
6	P16362	Divisão Central Dir.	Central Division Dir.	División Central Dir.	1	2097	450	12	MDP
7	P14678	Moldura Superior	Upper Frame	Marco superior	1	2504	103	15	MDF
8	P14666	Tampo Superior	Upper Floor	Tapa superior	1	2474	528	15	MDP
9	P14667	Tampo Inferior	Lower Top	Tapa Inferior	1	2474	528	15	MDP
10	P16371	Tampo Intermediário	Intermediate Top	Tapa	2	712	450	15	MDP
11	P16373	Tampo (1 ld s/ Pint.)	Top (1 ld s/ Pint.)	Tapa (1 ld s/ Pint.)	2	306	386	12	MDP
12	P16374	Tampo	Top	Tapa	2	306	386	12	MDP
13	P16360	Tampo Calceiro 1 ld	Table Top 1 ld	Tapa de Caldera 1 ld	1	712	250	12	MDP
14	P16377	Tampo Sup. Calceiro	Top Shoe Cover	Tapa Sup.Caldera	1	360	450	12	MDP
15	P16358	Tampo	Top	Tapa	2	390	450	12	MDP
16	P16357	Distanciador Pintado	Painted Spacer	Distanciador Pintado	4	648	70	15	MDP
17	P15411	Distanciador s/ Pint.	Sprayer without paint	Dist. sin pintura	4	648	70	15	MDP
18	P16356	Frente Gaveta	Drawer Frontal	Frente del Cajón	8	298	157	15	MDP
19	P16375	Lateral Gaveta	Side Drawer	Lateral del Cajón	16	325	88	12	MDP
20	P16366	Fundo Gaveta	Bottom Drawer	Fondo del Cajón	8	249	343	2,5	MDF
21	P16376	Traseiro Gaveta	Rear Drawer	Traseo del Cajón	8	251	88	12	MDP
22	P16368	Fundo Central	Central Fund	Fondo Central	1	2125	402	2,5	MDF
23	P16369	Fundo Lateral	Lateral Background	Fondo Lateral	4	2125	359	2,5	MDF
24	P16370	Fundo Menor	Minor Fund	Fondo Menor	2	2125	318	2,5	MDF
25	P16364	Divisão Calceiro	Shoe fittings	División Calzado	1	776	450	12	MDP
26	P16365	Prateleira Lateral	Side Shelf	Estante Lateral	1	353	450	12	MDP
27	P16359	Prateleira Maior	Largest Shelf	Estanteria Mayor	2	390	450	12	MDP
28	P16372	Prateleira Menor	Small Shelf	Estante Menor	4	306	386	12	MDP
29	P14683	Divisão Pé	Foot Division	División Pie	4	498	85,5	15	MDP
30	P14685	Traseiro Pé	Rear Foot	Trasero Pie	1	2474	85,5	15	MDP
31	P14684	Frente Pé	Front foot	Frente Pie	1	2474	85,5	15	MDP
32	P16354	Porta Central	Central Door	Puerta central	1	2082	400	15	MDP
33	P16355	Porta Lateral	Side door	Puerta lateral	2	1435	300	15	MDP

Roupeiro Sognare Carvalho Sensitive c/ Off White

34	P14789	Porta Superior Maior	High Door Bigger	Puerta Sup. Mayor	2	1040	715	12	MDP
35	P14790	Porta Inferior Menor	Lower Door Smaller	Puerta Inf. Menor	2	839	715	12	MDP
36	P14791	Aplicação Maior	Apply Greater	Aplicae Mayor	2	491	201	9	MDF
37	P14792	Aplicação Menor	Apply Minor	Aplicae Menor	2	139	201	9	MDF
38	34846	Espelho	Mirror	Espejo	2	250	105	2	VIDRO

Roupeiro Sognare Glass Carvalho Sensitive c/ Off White

34	P14789	Porta Superior Maior	High Door Bigger	Puerta Sup. Mayor	2	1040	715	12	MDP
35	P14790	Porta Inferior Menor	Lower Door Smaller	Puerta Inf. Menor	2	839	715	12	MDP
36	P14791	Aplicação Maior	Apply Greater	Aplicae Mayor	2	491	201	9	MDF
37	P14792	Aplicação Menor	Apply Minor	Aplicae Menor	2	139	201	9	MDF
38	34846	Espelho	Mirror	Espejo	2	250	105	2	VIDRO
39	34847	Espelho Menor	Small Mirror	Espejo Menor	2	519	398	3	VIDRO
40	34848	Espelho Maior	Large Mirror	Espejo Mayor	1	1038	398	3	VIDRO



Atenção com a cor do acabamento!
Em caso de assistência solicitar o código de acordo com a cor da peça/
Pay attention to the color of the finish!
In case of assistance request the code according to the color of the part/
Atención con el color del acabado!
En caso de asistencia solicitar el código de acuerdo con el color de la pieza.

Cod. Qnt.	A 12	B 122	C 32	D 28	E 16	F 34	G 4	H 48	I 35



Ferramentas necessárias (Não fornecidas)
Tools Required (Not Provided)
Herramientas necesarias (no incluidas)



Medidas em mm

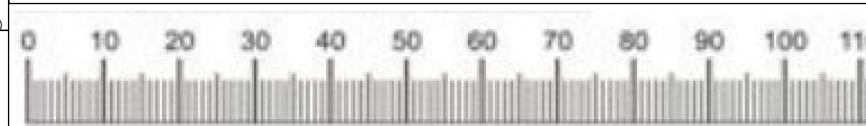

Roupeiro Sognare Glass 5 Portas / Wardrobe Sognare Glass 5 Doors / Ropero Sognare Glass 5 Puertas

1º Passo / Step / Paso

Inicie a montagem fixando as Divisões Pé (29), no Tampo Inferior (9), com Parafuso (D). Logo fixe Frente Pé (31) e Traseiro pé (30) na Divisão Pé (29), com Parafuso (B) e Cantoneira (Y) /

Start fixing the mounting foot Divisions (29), Bottom Surface (9) with screw (D). Logo fixing front Foot (31) and Rear Foot (30) in Division Foot (29), with Screw (B) and Angle (Y) /

Inicie el montaje fijando las Divisiones Pie (29), en el Tablero Inferior (9), con Tornillo (D). Luego fije frente a pie (31) y trasero pie (30) en la División Pie (29), con Tornillo (B) y Cantonera (Y) /

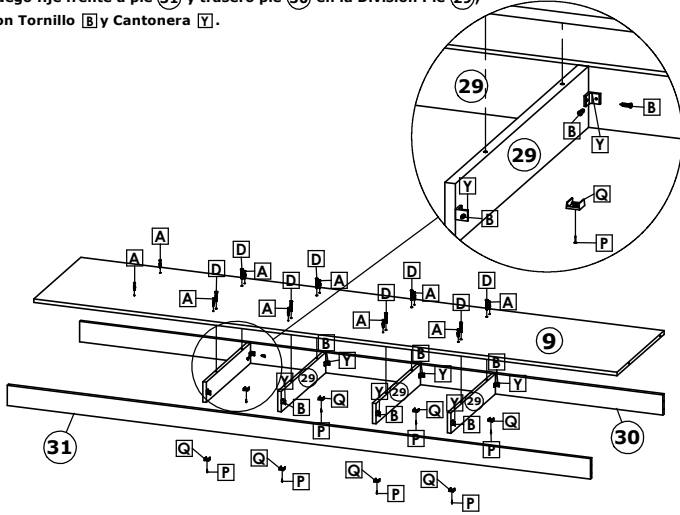

2º Passo / Step / Paso

Fixar Laterais (1 e 2), no Tampo Inferior (9), Frente pé (31) e Traseiro Pé (30), com Parafusos (D). Já os Tamos, (11, 13, 14 e 15), fixar com Parafuso (F) e Porca Cilíndrica (W) nas Divisões (3, 4, 5 e 6) /

Attaching Side (1 and 2), Bottom Surface (9), front foot (31) and rear foot (30), with screws (D). Since the tops (11, 13, 14 and 15), with fixing bolt (F) and the nut (W) Cylindrical Divisions (3, 4, 5 and 6) /

Fijar laterales (1 y 2), en el tapa inferior (9), frente pie (31) y trasero pie (30), con tornillos (D). En los tapas (11, 13, 14 y 15), fijar con Tornillo (F) y Tuerca Cilíndrica (W) en las Divisiones (3, 4, 5 y 6) /

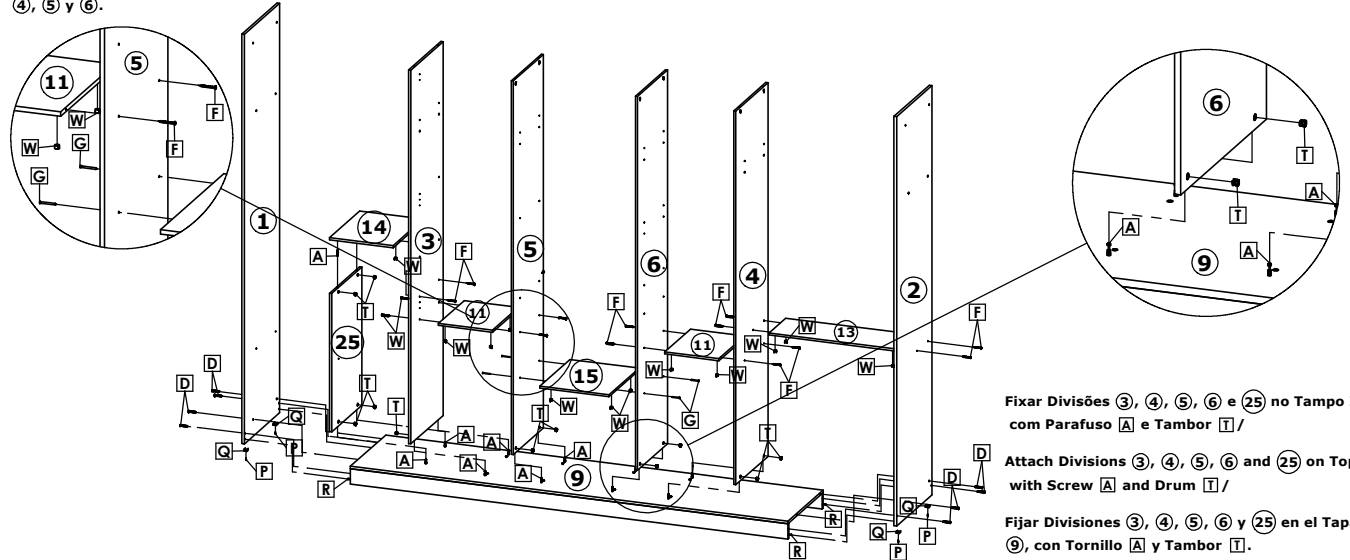

Fixar Divisões (3, 4, 5, 6 e 25) no Tampo Inferior (9), com Parafuso (A) e Tambor (T) /

Attach Divisions (3, 4, 5, 6 and 25) on Top (9), with Screw (A) and Drum (T) /

Fijar Divisiones (3, 4, 5, 6 y 25) en el Tapas Inferior (9), con Tornillo (A) y Tambor (T) /

3º Passo / Step / Paso

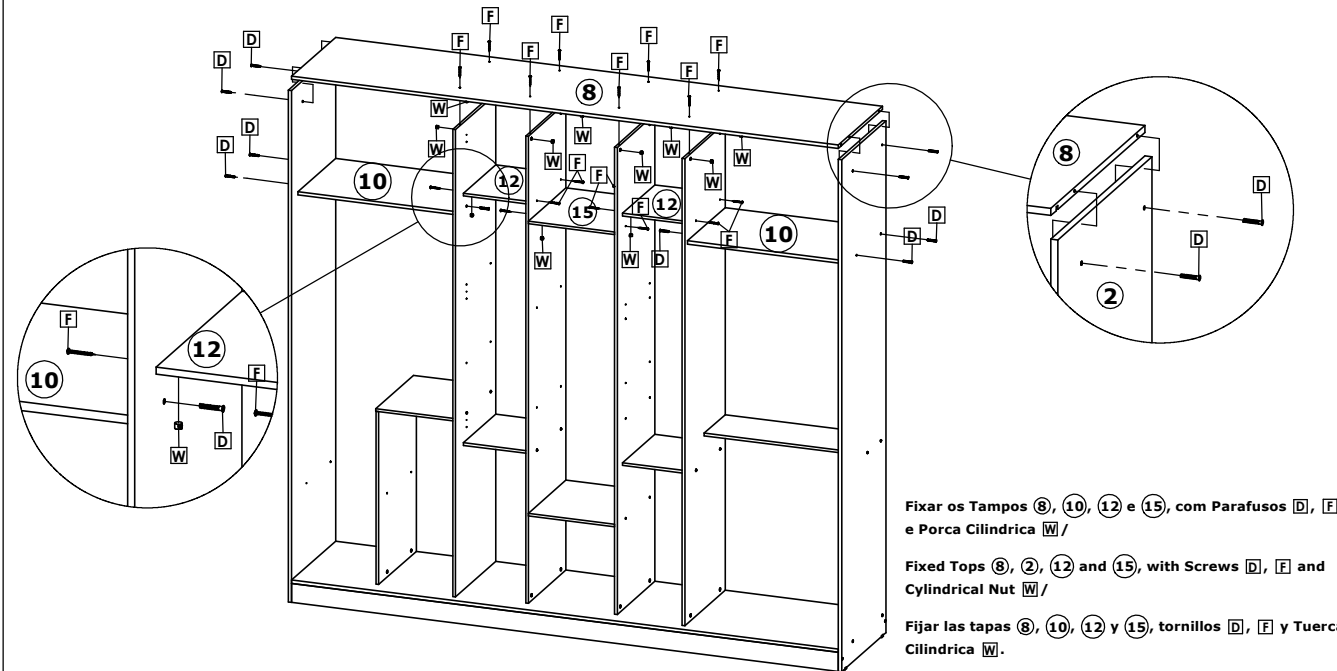

Fixar os Tamos (8, 10, 12 e 15), com Parafusos (D), F e Porca Cilíndrica (W) /

Fixed Tops (8, 10, 12 and 15), with Screws (D), F and Cylindrical Nut (W) /

Fijar las tapas (8, 10, 12 y 15), tornillos (D), F y Tuerca Cilíndrica (W) /

4º Passo / Step / Paso

Usar Pregos (P), Presilha (Q) e Perfil H (AL) na fixação dos Fundos (22, 23 e 24) /

Use Nail (P), Clamp (Q) and Profile H (AL) in the setting of Backgrounds (22, 23 and 24) /

Utilizar el clavo (P), la pletina (Q) y el perfil H (AL) en la fijación de los Fondos (22, 23 y 24) /

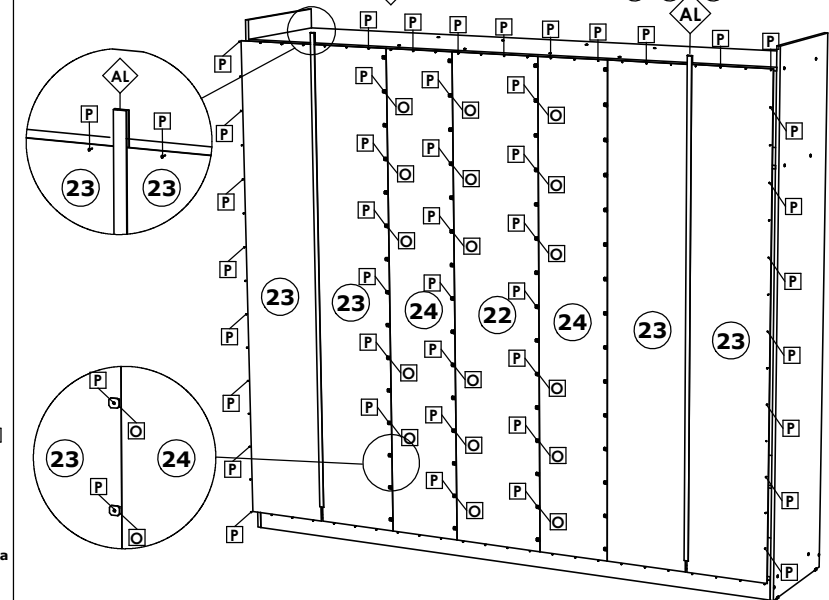

Roupeiro Sognare Glass 5 Portas / Wardrobe Sognare Glass 5 Doors / Ropero Sognare Glass 5 Puertas

5º Passo / Step / Paso

A Moldura ⑦ possui um rasgo, que serve de guia no posicionamento da Cantoneira ⑧ /
 Frame ⑦ has a slit, which serves as a guide in the positioning of the angle bracket ⑧ /
 El marco ⑦ tiene un rasgo, que sirve de guía en el posicionamiento de la Cantonera ⑧.

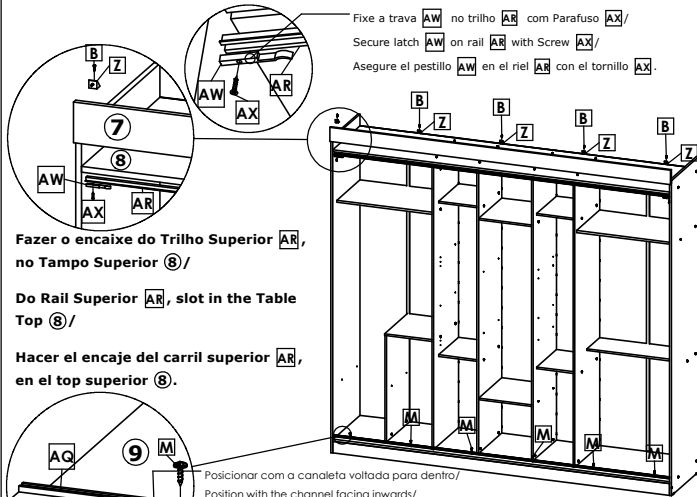

Fazer o encaixe do Trilho Superior AR, no Tampo Superior ⑧ /
 Do Rail Superior AR, slot in the Table Top ⑧ /

Do Rail Superior AR, slot in the Table Top ⑧ /

Hacer el encaje del carril superior AR, en el top superior ⑧.



Posicionar com a canoleta voltada para dentro /
 Position with the channel facing inwards /
 Posición con el canal mirando hacia el interior.

Posicionar o Trilho Inferior AQ á 15mm da borda do Tampo Inferior ⑨ /

Position the Bottom Rail AQ to 15mm from the Bottom Top ⑨ /

Posicionar el Carril Inferior AQ a 15mm del borde del Top Inferior ⑨.

7º Passo / Step / Paso

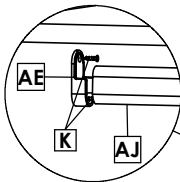

Encostar o Gabarito N em baixo dos Tamos ⑩, ⑬, ⑭ e nos Fundos do Roupeiro.

Com uma Ponteira você irá marcar as Laterais e Divisões.

Logo fixar com Parafusos K e Suportes AE nas marcações /

Layer Template N under Covers ⑩, ⑬, ⑭ and Bottom of the Wardrobe.

With a Pointer you will mark the Sides and Divisions.

Then fasten with Screw K and Brackets AE on the markings /

Colocar el Gabarito N debajo de los Tableros ⑩, ⑬, ⑭ y en el Fondo del Ropero.

Con un Puntero usted marcará las Laterales y Divisiones.

Luego fijar con Tornillo K y Soportes AE en las marcas.

N



ENCOSTAR NO TAMPO
 MARK THIS SIDE TO THE TOP
 APROXIMAR ESTE LADO DE LA TAPA

GABARITO P/ FIXAR CABEIRO
 MARK TO INSTALL HANGER
 UTILIZAR ESTA MARCACION PARA FIJAR COLGADOR

ENCOSTAR NO FUNDO
 MARK THIS SIDE TO THE TOP
 APROXIMAR ESTE LADO DEL FONDO

ENCOSTAR NO FUNDO
 MARK THIS SIDE TO THE TOP
 APROXIMAR ESTE LADO DEL FONDO

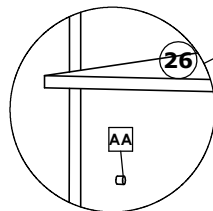

6º Passo / Step / Paso

Montagem das Gavetas / Mounting the Drawers / Montaje del Cajón.

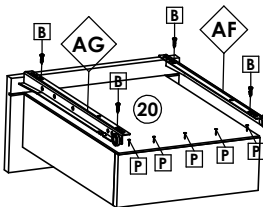
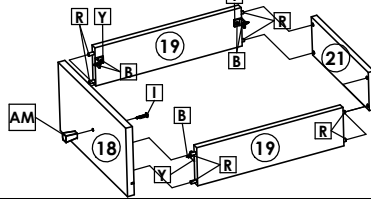

Montagem do Distanciador / Mounting the Spacers / Montaje del espaciador.

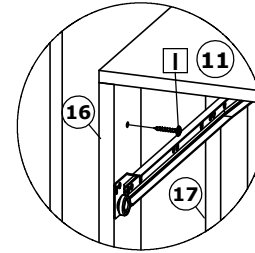
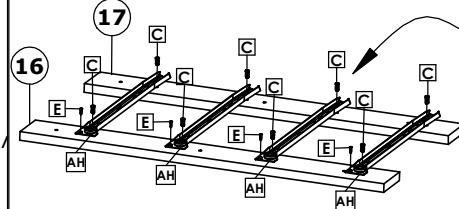

Posicionar o Distanciador 16 paralelo ao Tampo 11 /

Position Spacer 16 parallel to Top 11 /

Posicionar el Distanciador 16 paralelo al Tablero 11.

Faça a montagem externa do conjunto distanciador+corrediça, alinhando as corrediças pelo segundo furo.
 Após faça a fixação do conjunto com parafusos E e C.

Write external mounting of the spacer + slide assembly aligning the slides through the second hole.
 After securing the assembly with screws E and C /

Haga el montaje externo del conjunto distanciador + corredera, alineando las diapositivas por el segundo agujero.
 Después de hacer la fijación del conjunto con tornillos E y C.

Peso Suportado / Weight supported / peso que soporta

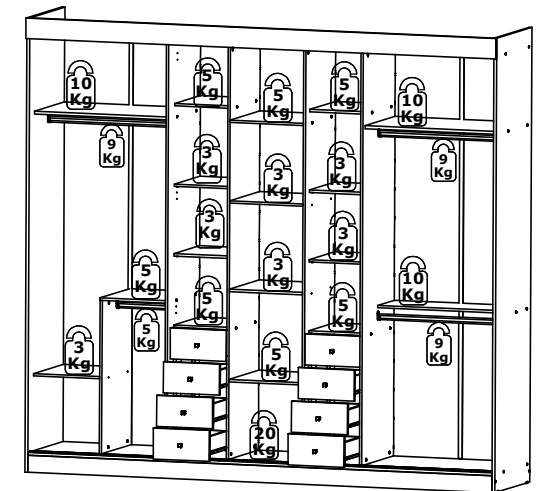

Peso Suportado por cada gaveta /
 Weight Supported per drawer /
 Peso soportado por cada cajón.



Roupeiro Sognare Glass 5 Portas / Wardrobe Sognare Glass 5 Doors / Ropero Sognare Glass 5 Puertas

Montagem Portas Sognare / Doors Sognare / Puertas Sognare

Usar Dobradiças Super Curva **AC**, na montagem das Portas **(33)** /
Use hinges Super Curve **AC**, in the assembly of doors **(33)** /
Uso de las bisagras Super Curva **AC**, en el montaje de las Puertas **(33)**.

Usar Dobradiças Mini Curva **AD**, na montagem das Portas **(32)** /
Use hinges Mini Curve **AD**, in the assembly of doors **(32)** /
Uso de las bisagras Mini Curva **AD**, en el montaje de las Puertas **(32)**.

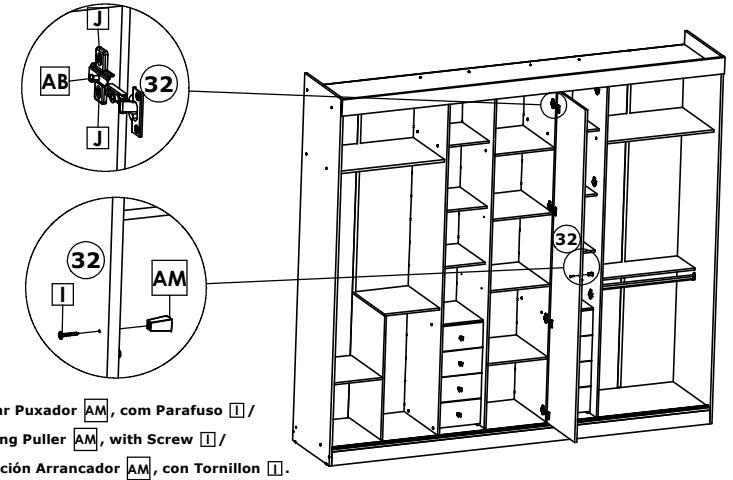
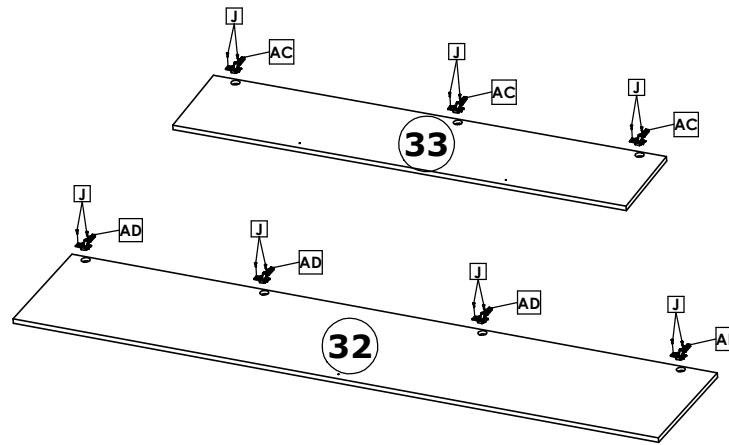

Fixar Puxador **AM**, com Parafuso **I** /
Fixing Puller **AM**, with Screw **I** /
Fijación Arrancador **AM**, con Tornillon **I**.

Montagem Portas Sognare / Doors Sognare / Puertas Sognare

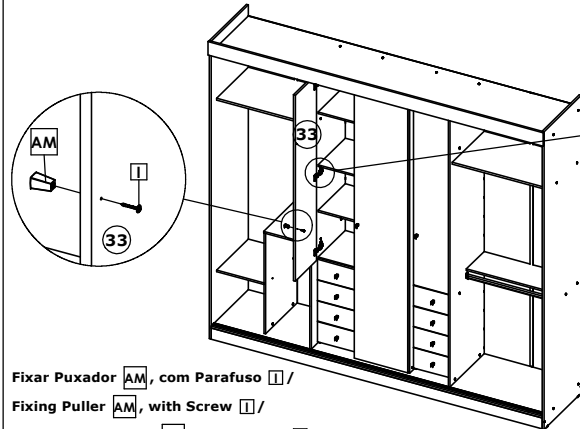

Fixar Puxador **AM**, com Parafuso **I** /
Fixing Puller **AM**, with Screw **I** /
Fijación Arrancador **AM**, con Tornillo **I**.

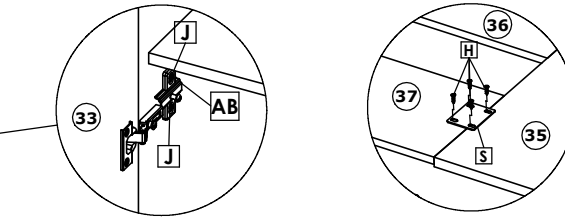

Fixar Chapa Junção **S**, nos Apliques **(36)** e **(37)**, em seguida fixar Apliques nas Portas **(34)**, **(35)**.
Os Apliques ficarão com um recuo de 3mm na parte Frontal, em relação as portas /

Attach Plate **S**, in the Walls **(36)** and **(37)**, then fix Walls on the Doors **(34)**, **(35)**.
The appliqué will have a 3mm indentation on the front, relative to the doors.

Fijar Chapa Juncción **S**, en los Apliques **(36)** y **(37)**, luego fijar Apliques en las Puertas **(34)**, **(35)**.
Los Apliques quedarán con un retroceso de 3mm en la parte frontal, en relación a las puertas.

É de extrema importância que as Portas sejam montadas sobre uma superfície plana /
It is extremely important that the Doors are mounted on a flat surface /
Es de extrema importancia que las Puertas sean montadas sobre una superficie plana.

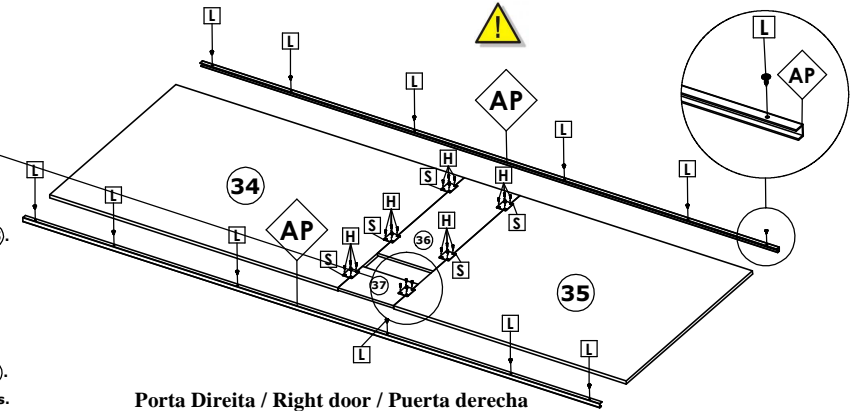

Porta Direita / Right door / Puerta derecha

Montagem Portas Sognare / Doors Sognare / Puertas Sognare

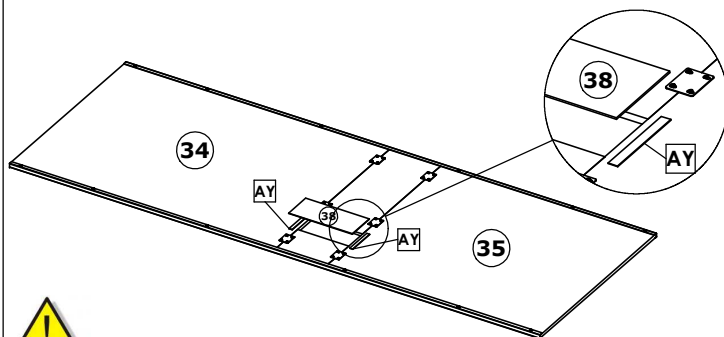

Iniciar a montagem dos Guias Superiores **AS** 4mm com Capa Branca posicionando à 32mm da Cantoneira **AP**.
Após fixar os Guias Superiores **AV** 6mm com Capa Cinza na parte central das Portas, posicionando à 64mm da Cantoneira **AP** /

Start the assembly of the Top Guides **AS** 4mm with White Cover positioning to the 32mm of the Angle **AP**.
After fixing the 6mm Top Guides **AV** with Gray Cover in the central part of the Doors, positioning to the 64mm of the Corner **AP** /

Iniciar el montaje de las guías superiores **AS** 4mm con tapa blanca colocando a la 32mm de la cantonera **AP**.
Después de fijar las guías superiores **AV** 6mm con capa gris en la parte central de las puertas, colocando a la 64mm de la cantonera **AP**.

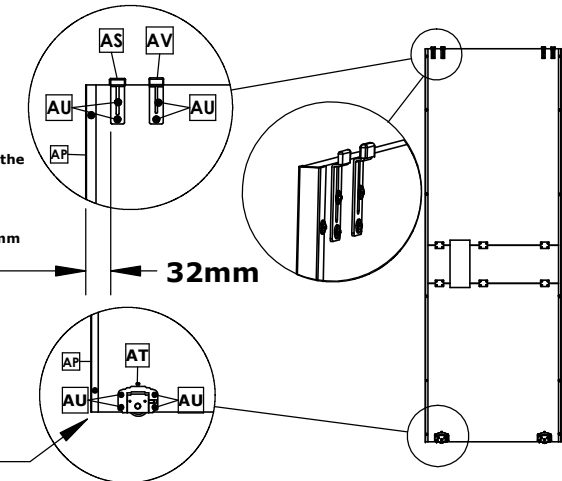

Posicionar o Rodízio Inferior **AT** à 32mm da Cantoneira **U AP** /
Position the Rod Less than **AT** 32mm from the U-bracket **AP** /
Posicionar el Rodamiento Inferior **AT** a la 32mm de la Cantoneira **U AP**.





Porta Direita / Right door / Puerta derecha

As Portas de Correr possuem em sua extremidade um espaço onde deve ser aplicado o Espelho **(38)**, com Fita Dupla Face **AY** /
The Sliding Doors have, and their end, a space where the Mirror **(38)**, with Double Face Tape **AY** should be applied.

Las Puertas de Correr poseen y su extremo un espacio donde debe ser aplicado el Espejo **(38)**, con Cinta Doble Cara **AY**.

Roupeiro Sognare Glass 5 Portas / Wardrobe Sognare Glass 5 Doors / Ropero Sognare Glass 5 Puertas

Inicie a montagem alinhando o Espelho (39), ao Topo da Porta (32).
 Logo posicione os demais Espelhos (40) e (39) deixando 3mm de folga entre eles/
 Start the assembly by aligning the Mirror (39), to the Top of the Door (32).
 Then position the other mirrors (40) and (39) leaving 3mm of gap between them/
 Inicie el montaje alineando el espejo (39), al principio de la puerta (32).
 Luego coloque los demás Espejos (40) y (39) dejando 3mm de holgura entre ellos.

- AZ 12
-  Suporte Pino Vidro 25678
- AAA 12
-  Parafuso 3,5x14 CP (Zincado Branco) 34125
- AAB 1
- X1  X2
- 1 Kit Puxador + Parafuso 25644/25734

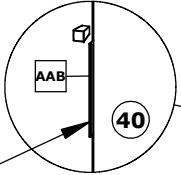

Obs. O puxador AAB acompanha o kit de espelhos/
 Note Handle AAB comes with the mirror kit/
 Nota El mango AAB viene con el kit de espejo.

Quando o roupeiro for na versão Glass, deve ser usado o Perfil Puxador AAB na Porta Central (32)/
 When the wardrobe is in the Glass version, the Handle Profile AAB in the Central Door (32)/
 Cuando el armario es en la versión Glass, debe ser usado el Perfil Tirador AAB en el puerto central (32).

Sognare Glass

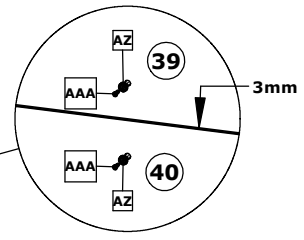
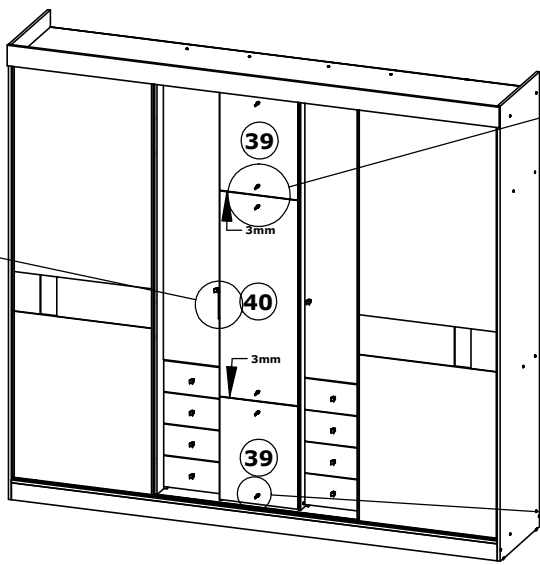

Usar Parafuso AAA e Suporte Pino AZ na fixação dos Espelhos (39) e (40)/

Using Screw AAA Pin Support AZ fixing the Mirrors (39) and (40)/

Utilizar Tornillo AAA y Soporte Pino AZ en fijación de los espejos (39) y (40).

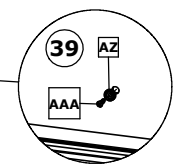

Sognare

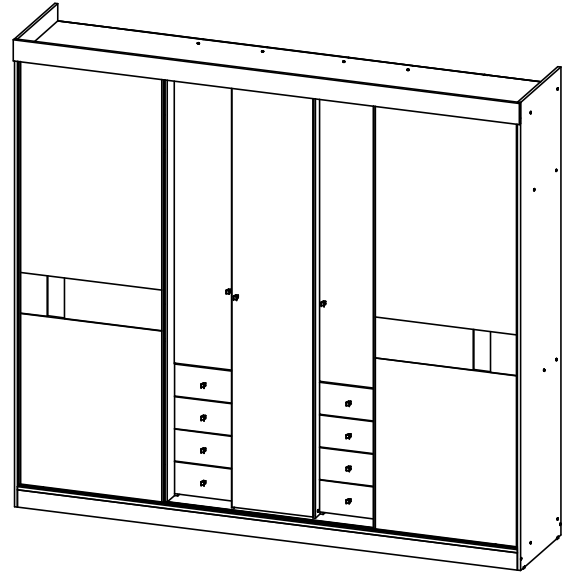

Montagem Pés Sognare / Mounting Feet Sognare / Montaje Pies Sognare.



Os Pés são opcionais e podem ou não acompanhar o produto, depende da versão que você está adquirindo/
 Feet are optional and may or may not accompany the product, depending on the version you are purchasing/
 Los Pies son opcionales y pueden o no acompañar el producto, depende de la versión que usted está adquiriendo.

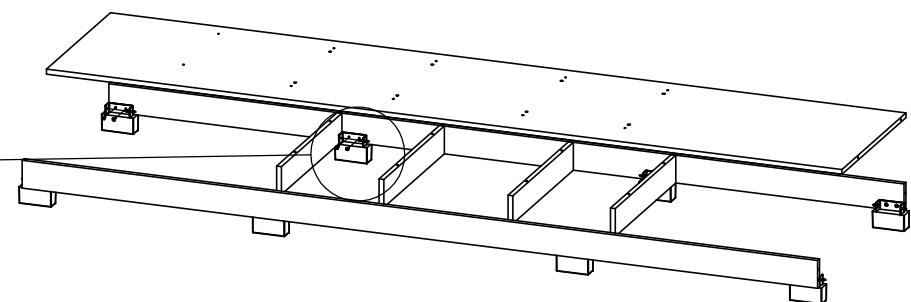
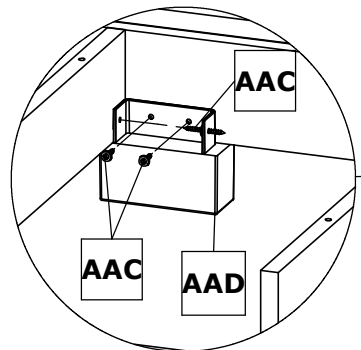
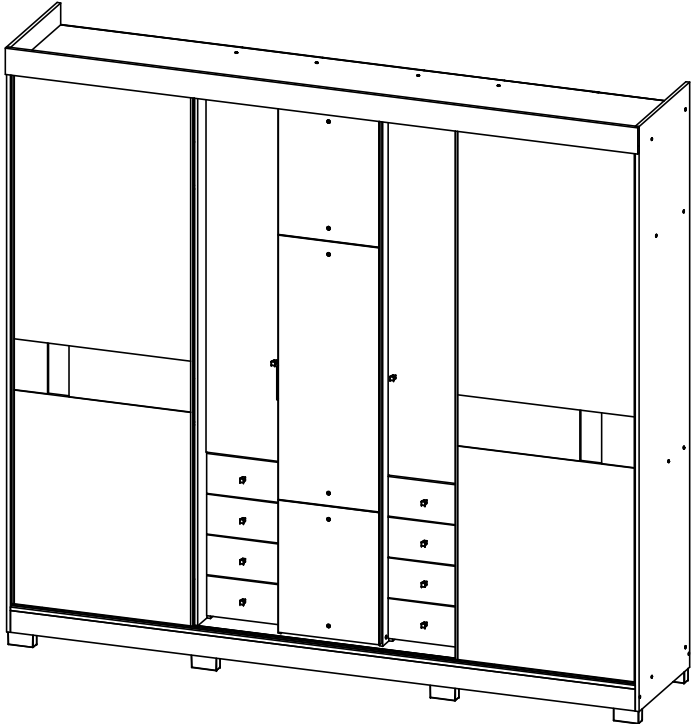

Na opção com Pés, fixar pés AAD com Parafusos AAC /
 In the option with Feet, fix feet AAD with Screws AAC /
 Na opção com Pés, fixar pés AAD com Parafusos AAC.

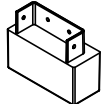
- | | | | |
|---|----|---|---|
| AAC | 24 | AAD | 8 |
|  | |  | |
| Parafuso 4,0x12 CF 30518 | | Pé Retangular 34700 | |