

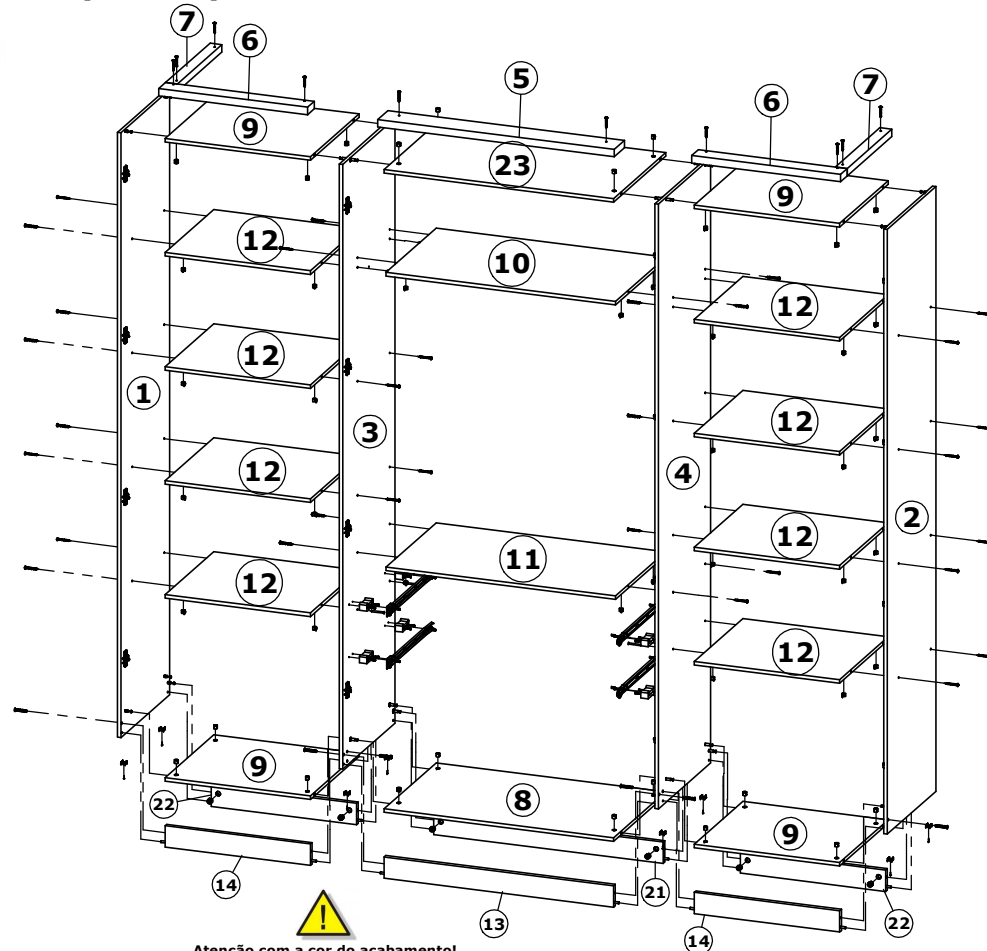

# Roupeiro Splendore 4 Portas / Wardrobe Splendore 4 Doors / Ropero Splendore 4 Puertas

segunda-feira, 17 de fevereiro de 2025



**Atenção com a cor do acabamento!**  
**Em caso de assistência solicitar o código de acordo com a cor da peça /**  
**Pay attention to the color of the finish!**  
**In case of assistance request the code according to the color of the part /**  
**Atención con el color del acabado!**  
**En caso de asistencia solicitar el código de acuerdo con el color de la pieza.**

Cod. Qnt.

A   10  Parafuso Biofix 33160	B   24  Parafuso 3,5x12 CP 33297	C   2  Puxador Ponto Canaan 34530 - Cromado	D   6  Parafuso Soberbão 7x40 25691	E   76  Parafuso 4,0x12 CC 30189	F   36  Parafuso 4,0x45 CF 33292 - Zincado Amarelo 33194 - Zincado Branco	G   4  Parafuso 4,0x45 CC 33596 - Zincado Amarelo 33002 - Zincado Branco	H   28  Cavilha 6x30 24603	I   2  Parafuso 3,5x25 CF (Puxador Ponto Canaan) 24648
J   10  Parafuso 4,0x35 CF 29815	K   4  Parafuso 3,5x10 CC 36722 (Emb. c/ Sup. Cabideiro)	L   4  Parafuso 3,5x30 CF 25700 (Puxador Citrino)	M   18  Parafuso 3,5x14 CP 34125 - Zincado Branco	N   10  Paraf. Minifix Haste Dupla 30198	O   40  Presilha Fundo 24099	P   150  Prego 10x10 20179	Q   8  Sapata Plástica 12x12 33640 - Carvalho 32278 - Branco	R   2  Sache de cola 10g 25676
S   6  Tambor Minifix 15mm 22388	T   24  Tambor Minifix 12mm 30182	U   24  Tampa Tambor Minifix 36012 - Linho	V   4  Tampa Soberbão 33290 - Carvalho 27089 - Branco	W   2  Suporte Triângular 30094	X   40  Porca Cilíndrica 36008 - Linho	Y   8  Cantoneira Plástica 36010 - Linho	Z   16  Calço p/ Dobradilha 23273	AA   16  Dobradilha Baixa 23271
AB   2  Suporte Cabideiro 36611	AC   1  Adesivo Logotipo THB 31363	AD   2  Corredilha 400mm 21611	AE   8  Distanciador 25mm 37492	AF   2  Puxador Citrino 512mm 24904 - Alumínio 28717 - Ponteira Crom.	AG   3  Perfil H 1964mm 34804 - Champagne	AH   1  Cab. Oblongo 772mm 35138		

## Roupeiro Splendore

Peça / Piece / Pieza	Branco	Carvalho	Descrição	Description	Descripción	Qtde Qty Cant	Compr Length Largo	Larg. Width Ancho	Esp. Thickness Espesor
1	P17514	P16386	Lateral Esquerda	Left Panel	Lateral Izquierda	1	2036	436	12
2	P17515	P16389	Lateral Direita	Right Panel	Lateral Derecha	1	2036	436	12
3	P17512	P16380	Divisão Esquerda	Left Division	Division Izquierda	1	2036	468	12
4	P17513	P16385	Divisão Direita	Right Division	Division Derecha	1	2036	468	12
5	P15474	P14735	Moldura Sup. Central	Central Beam Frame	Marco suprimido	1	803	92	25
6	P15476	P14736	Moldura Sup. Menor	Smallest Sup. Frame	Marco Sup. Menor	2	505	60	25
7	P15475	P14737	Moldura Sup. Lateral	Side Superstructure	Lámpara Sup. Lateral	2	401	30	25
8	P16390	P16390	Tampo Inf Central	Top Inf Central	Tapa Inf Central	1	779	468	12
9	P16387	P16387	Tampo Sup/Inf Lat.	Sup / Inf Lateral Top	Tapa Sup / Inf Lateral	4	493	436	12
10	P16384	P16384	Tampo Intermediário	Intermediate Top	Tapa	1	779	450	12
11	P16383	P16383	Tampo (1ld s/Pintura)	Cover (One ld s/painted)	Tapa (1ld s/pintura)	1	779	450	12
12	P16388	P16388	Tampo Lateral	Lateral Top	Tapa lateral	8	493	436	12
13	P15473	P14727	Frente Pé Central	Front Center Foot	Frente Pie Central	1	779	72	15
14	P15472	P14726	Frente Pé Lateral	Front Side Foot	Del lado derecho	2	493	72	15
15	P16392	P16392	Frente Gaveta	Drawer Frontal	Frente del Cajón	2	723	149	12
16	P16060	P16060	Lateral Gaveta	Side Drawer	Lateral del Cajón	4	385	88	12
17	P16393	P16393	Fundo Gaveta	Bottom Drawer	Fondo del Cajón	2	704	403	2,5
18	P16391	P16391	Traseiro Gaveta	Rear Drawer	Traseo del Cajón	2	704	88	12
19	P16381	P16381	Fundo Central	Central Fund	Fondo Central	2	1964	392	2,5
20	P16382	P16382	Fundo Lateral	Lateral Background	Fondo Lateral	4	1964	249	2,5
21	P14731	P14731	Traseiro Pé Central	Rear Center Foot	Trasero Pie Central	1	779	72	15
22	P14728	P14728	Traseiro Pé Lateral	Rear Foot	Trasero Pie Lateral	2	493	72	15
23	P17543	P17543	Tampo Sup Central	Top Sup Central	Tapa Sup Central	1	779	468	12
24	P17510	P16394	Porta Lateral	Side Door	Puerta Lateral	2	1952	495	15
25	P17511	P16395	Porta Central	Central Door	Puerta Central	2	1952	394	15

## Espelhos Splendore Plus Glass

26	34801	Espelho Maior	Door/Large Mirror	Espejo Mayor	2	974	350	3
27	34802	Espelho Menor	Small Mirror	Espejo Menor	4	487	350	3

## Espelhos Splendore Glass

26	30919	Espelho Maior	Door/Large Mirror	Espejo Mayor	2	1348	350	3
----	-------	---------------	-------------------	--------------	---	------	-----	---

## Medidas em mm



Ferramentas necessárias (Não fornecidas) | Tools Required (Not Provided) | Herramientas necesarias (no incluidas)



m.motta

# Roupeiro Splendore 4 Portas / Wardrobe Splendore 4 Doors / Ropero Splendore 4 Puertas

## 1º Passo / Step / Paso

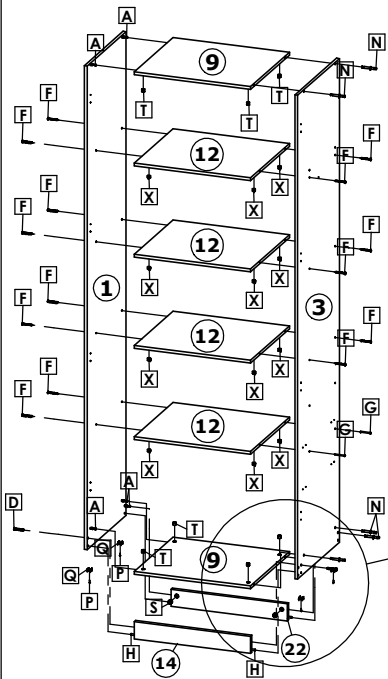

**Inicie a Montagem pelas Torres Laterais, fixando Laterais ① e ②, Divisões ③ e ④, nos Tornos ⑨ e ⑫, com Parafusos F, D, N e A /**

**Start the Assembly by the Side Towers, fixing Side ① and ②, Divisions ③ and ④, on Tops ⑨ and ⑫, with Screws F, D, N and A /**

**Inicie el Montaje por las Torres Laterales, fijando Laterales ① y ②, Divisiones ③ y ④, en los Tableros ⑨ y ⑫, con Tornillos F, D, N y A.**

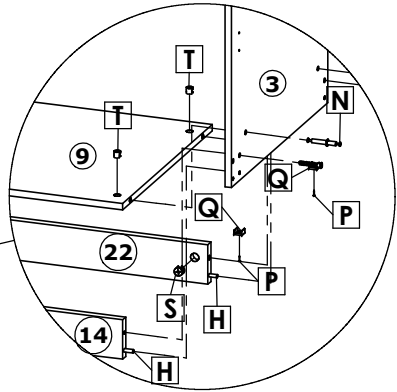

## 2º Passo / Step / Paso

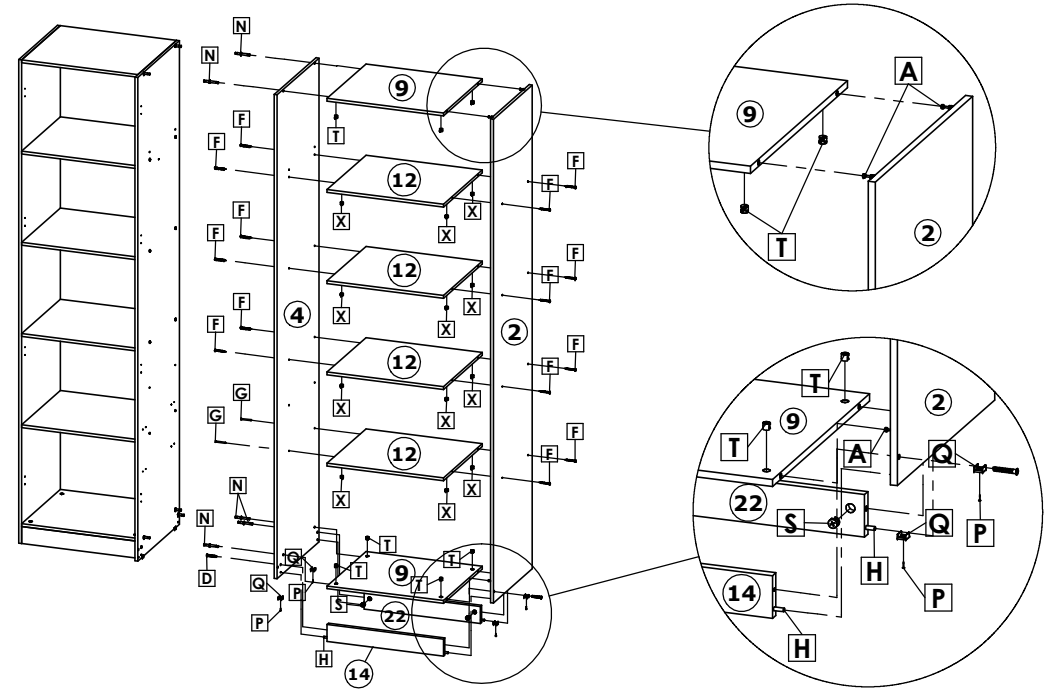

## 3º Passo / Step / Paso

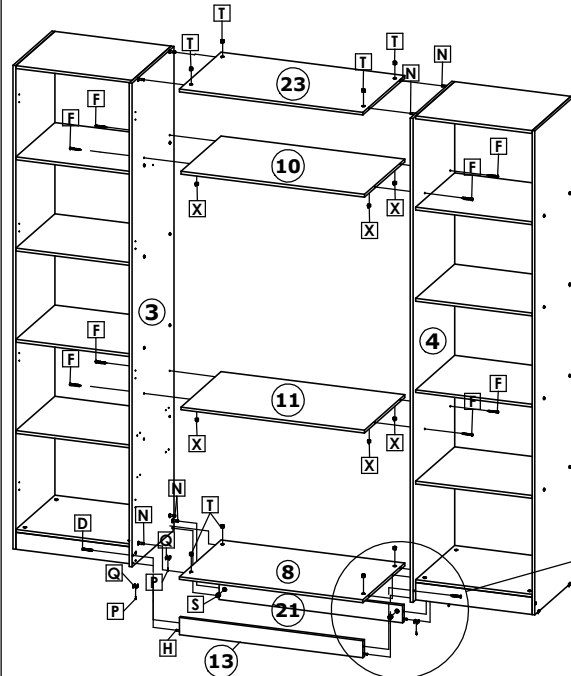

**Após a montagem das duas Torres Laterais, fixar os tornos Centrais (23, 8, 10 e 11) com Parafusos N, F e Tambor T. Já a Frente Pé (13) e Traseiro Pé (21), fixar com Parafusos D, N e Tambor S /**

**After the assembly of the two Side Towers, fix the Central tops (23, 8, 10 and 11) with Screws N, F and Drum T. Already the Front Foot (13) and Rear Foot (21), fix with Screws D, N and Drum S /**

**Después del montaje de las dos Torres Laterales, fijar las encimeras Centrales (23, 8, 10) y 11 con Tornillos N, F y Tambor T. En la parte frontal del pie (13) y trasero pie (21), fijar con tornillos D, N y tambor S.**

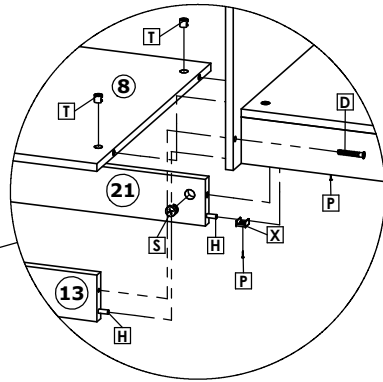

## 4º Passo / Step / Paso

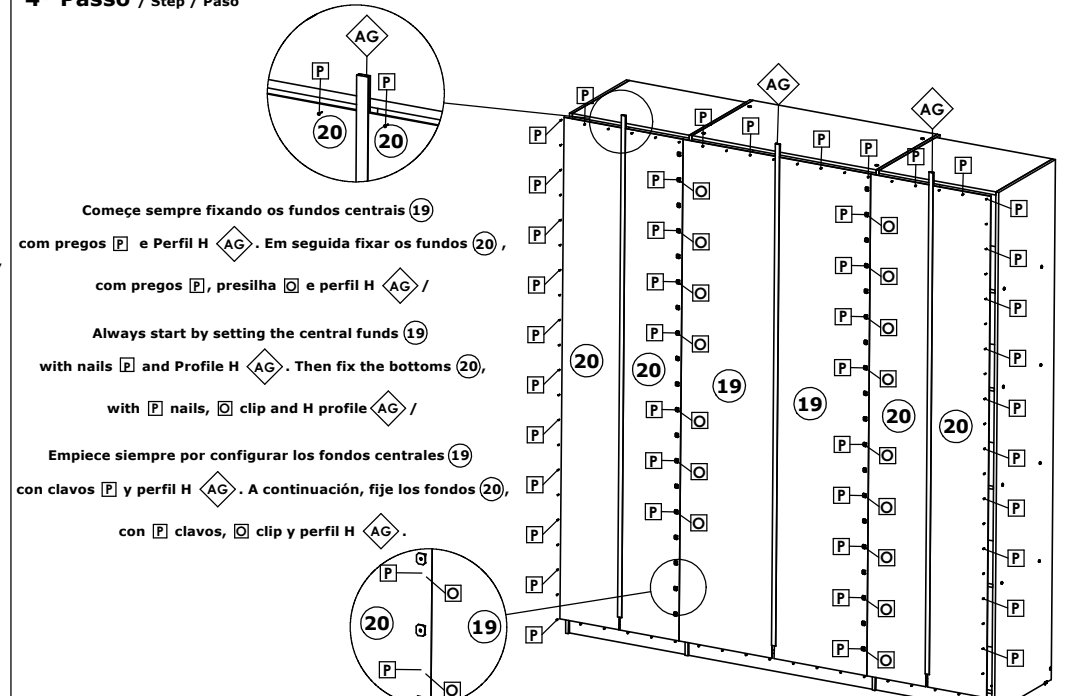

**Comece sempre fixando os fundos centrais (19) com pregos P e Perfil H AG. Em seguida fixar os fundos (20), com pregos P, presilha O e perfil H AG /**

**Always start by setting the central funds (19) with nails P and Profile H AG. Then fix the bottoms (20), with P nails, O clip and H profile AG /**

**Empiece siempre por configurar los fondos centrales (19) con clavos P y perfil H AG. A continuación, fije los fondos (20) con P clavos, O clip y perfil H AG.**

# Roupeiro Splendore 4 Portas / Wardrobe Splendore 4 Doors / Ropero Splendore 4 Puertas

## 5º Passo / Step / Paso

Após posicionar as Molduras Superior ⑤, ⑥ e ⑦, fixa-las com Parafuso J /  
 After positioning the Top Frames ⑤, ⑥ and ⑦, secure them with Screw J /  
 Después de colocar los Marcos Superior ⑤, ⑥ y ⑦, fijarlos con Tornillo J.

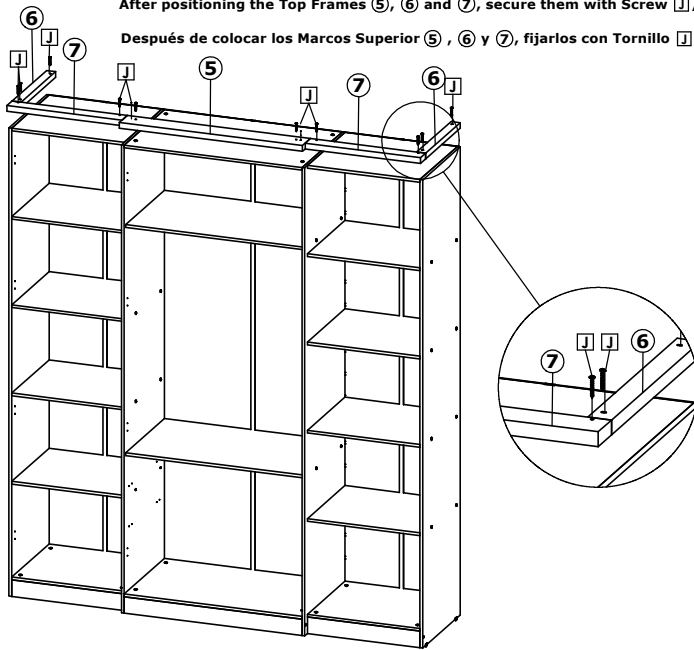

## 6º Passo / Step / Paso

Montagem das Gavetas / Mounting the Drawers / Montaje del Cajón.

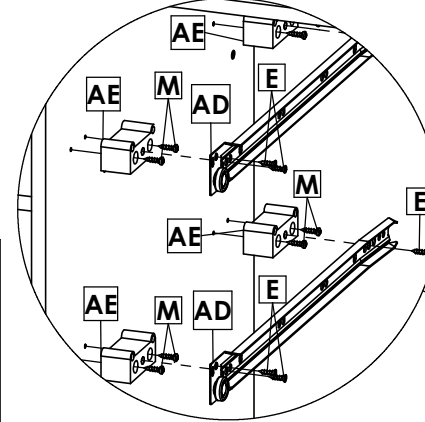
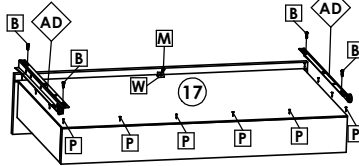
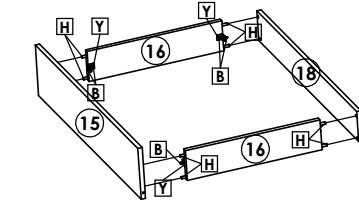

Fixar os distanciadores AE nas divisões ③ e ④, com parafusos M.  
 Logo fixar as correças AD e AE nos distanciadores AE com parafusos E /  
 Fix spacers AE in divisions ③ and ④, with screws M.  
 Then fix the slides AD and AE on the spacers AE with screws E /  
 Fije los espaciadores AE en las divisiones ③ y ④, con tornillos M.  
 Luego fije las diapositivas AD y AE en los espaciadores AE con tornillos E.

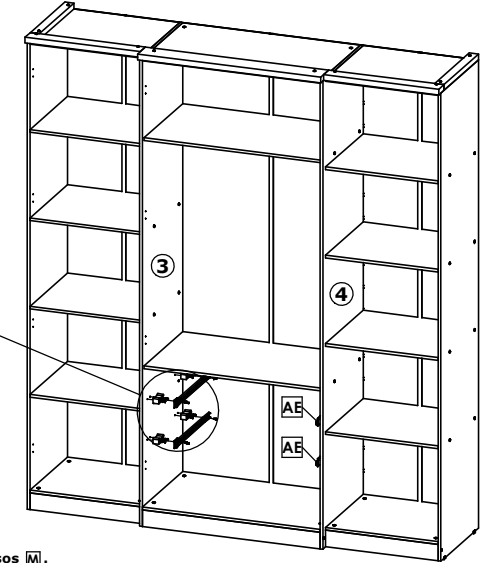

## 7º Passo / Step / Paso

Peso Suportado / Weight supported / peso que soporta



Fixar Suportes de Cabideiro AB, com Parafuso K nas Divisões ③ e ④ /  
 Attach Clothes Rack AB with Screw K in Divisions ③ and ④ /  
 Fijar Soportes de Cabezal AB, con Tornillo K en las Divisiones ③ y ④.

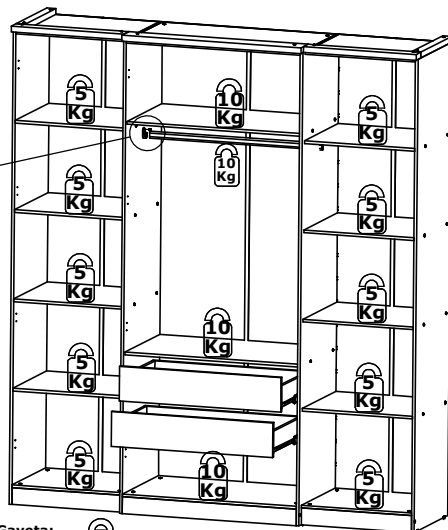
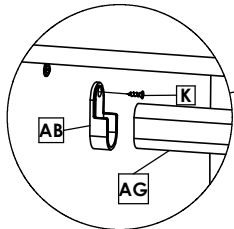

Peso suportado po cada Gaveta:  
 Weight supported by each Drawer:  
 Peso suportado por cada Cajón: 5 Kg

## Montagem Portas Splendore / Splendore Doors / Puertas Splendore

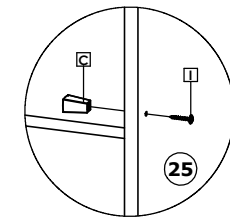
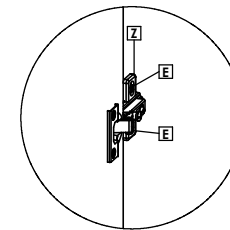
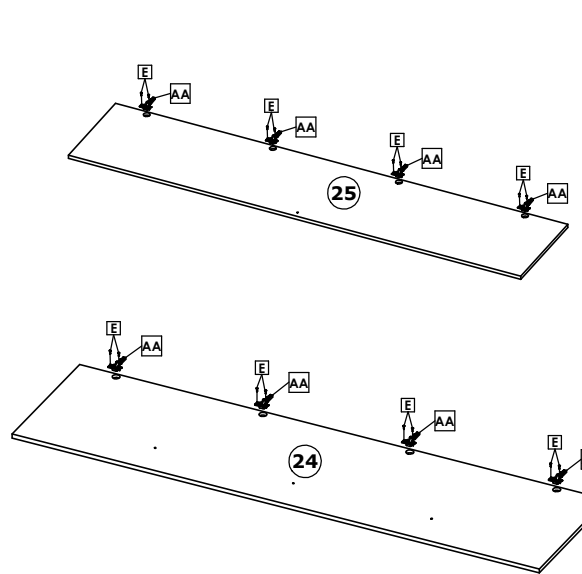

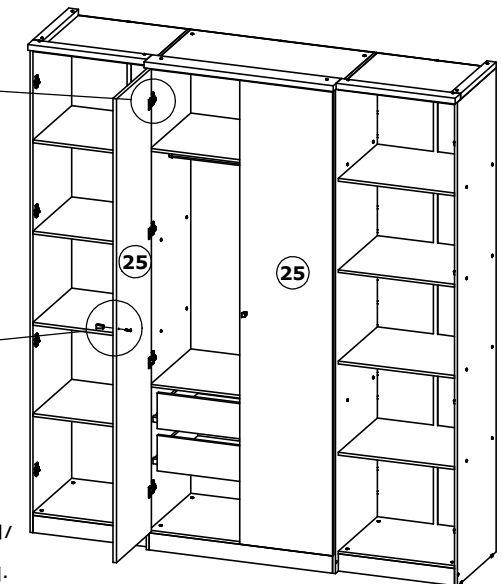

Fixar Puxador C, com Parafuso I /  
 Attach Knob C, with Screw I /  
 Fijación Tirador C, con Tornillo I.

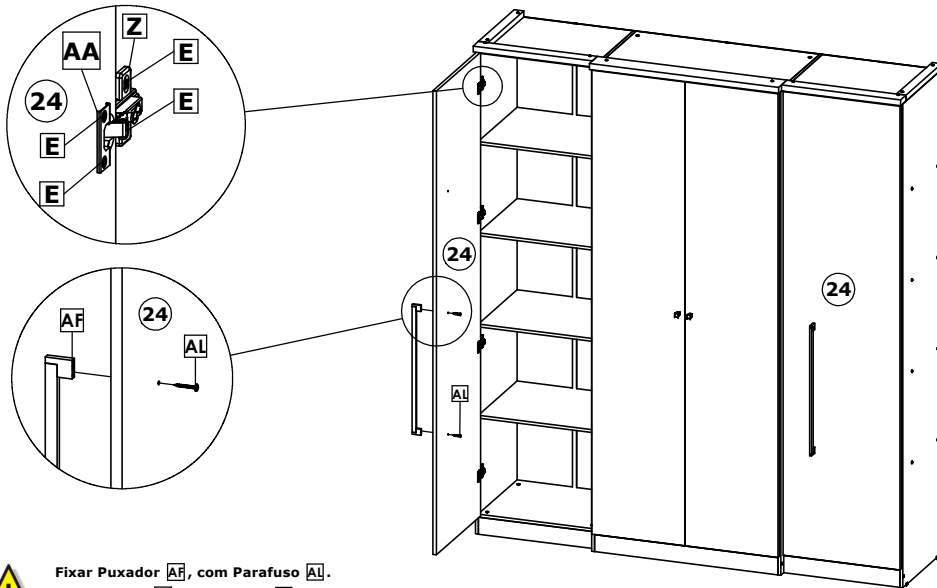

# Roupeiro Splendore 4 Portas / Wardrobe Splendore 4 Doors / Roper Splendore 4 Puertas

## Montagem Portas Splendore/ Splendore Doors / Puertas Splendore



-  Fixar Puxador AF, com Parafuso AL.  
Attach Knob AF, with Screw AL.  
Fijación Tirador AF, con Tornillo AL.

Posicione os Espelhos (26), à 302mm do Topo da Porta (25) e paralelo a lateral da Porta (25).

Logo fixe os Espelhos (26), com Parafusos AN e Suporte Vidro Pino AM /



Position Mirrors (26), 302mm from Top of Door (25) and parallel to side of Door (25).

Then secure the Mirrors (26), with Screws AN and Mount Glass Pin AM /

Coloque los espejos (26), a 302mm de la parte superior de la puerta (25) y paralelo al lateral de la puerta (25).

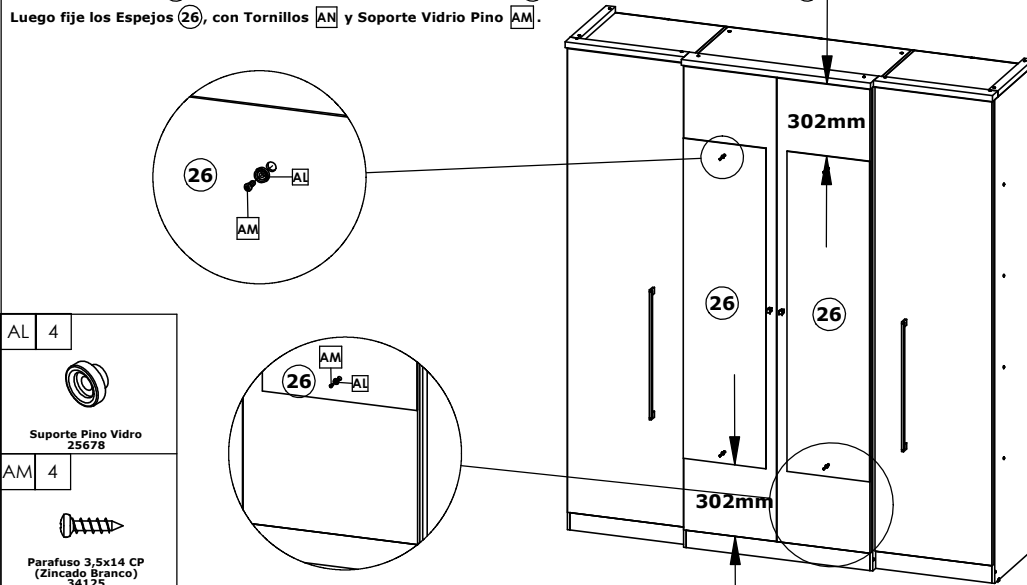
Luego fije los Espejos (26), con Tornillos AN y Soporte Vidrio Pino AM.



- |  |   |
|--|---|
| AL   | 4 |
|  |   |
| Suporte Pino Vidro 25678   |   |
| AM   | 4 |
|  |   |
| Parafuso 3,5x14 CP (Zincado Branco) 34125  |   |

Inicie a montagem alinhando os Espelhos Superior (27), com a Lateral e topo da Porta (25).



Logo inserir os Espelhos (26) e (27), fixando-os com Parafusos AM e Suporte Vidro Pino AL, deixando entre cada Espelho um espaçamento de 2mm / Start the assembly by aligning the Top (27), Mirrors with the Side and Top of Door (25).

Then insert Mirrors (26) and (27), securing them with Screws AM and Glass Pin Support AL, leaving between each Mirror a spacing of 2mm /

Inicie el montaje alineando los espejos (27) superior, con el lateral y la parte superior de la puerta (25).

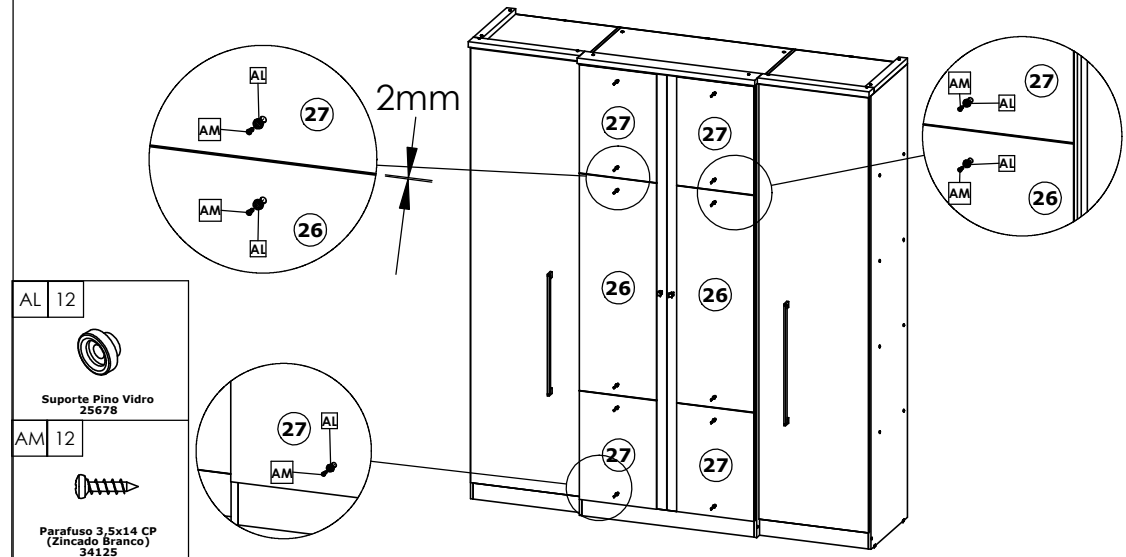
Luego inserte los Espejos (26) y (27), fijándolos con Tornillos AM y Soporte Vidrio Pino AL, dejando entre cada espejo un espaciamento de 2mm.



- |   |    |
|---|----|
| AL  | 12 |
|  |    |
| Suporte Pino Vidro 25678  |    |
| AM  | 12 |
|  |    |
| Parafuso 3,5x14 CP (Zincado Branco) 34125   |    |

Posicione os Espelhos (26), à 476mm do Topo da Porta (25) e 52mm da lateral da porta.

Logo fixe os Espelhos (26), com Parafusos AM e Suporte Vidro Pino AL /



Position Mirrors (26), 476mm from the Top of Door (25) and 52mm from the side of the door.

Then fix Mirrors (26), with Screws AM and Glass Support Pin AL /

Coloque los espejos (26), 476 mm desde la parte superior de la puerta (25) y 52 mm desde el costado de la puerta.

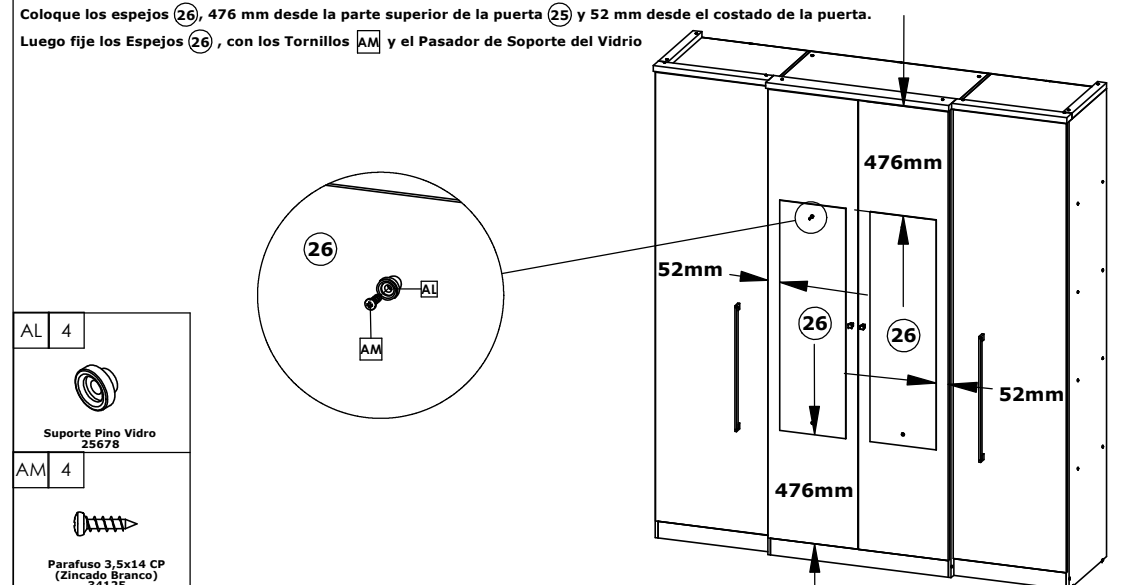
Luego fije los Espejos (26), con los Tornillos AM y el Pasador de Soporte del Vidrio



- |   |   |
|---|---|
| AL  | 4 |
|  |   |
| Suporte Pino Vidro 25678  |   |
| AM  | 4 |
|  |   |
| Parafuso 3,5x14 CP (Zincado Branco) 34125   |   |

**Roupeiro Splendore 4 Portas / Wardrobe Splendore 4 Doors / Ropero Splendore 4 Puertas**

**Splendore**

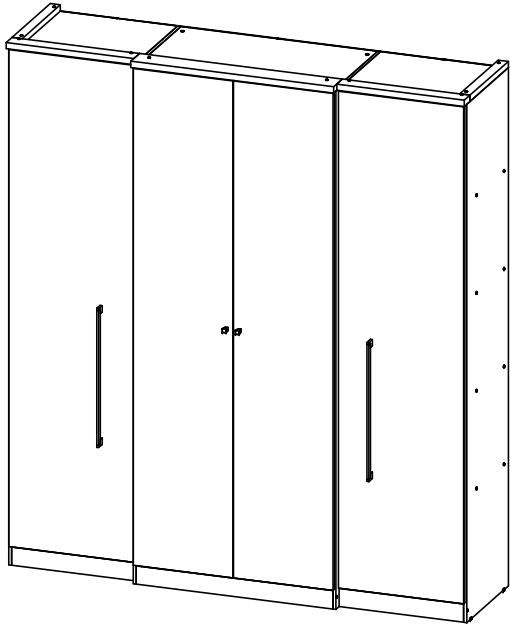

**Splendore Glass**

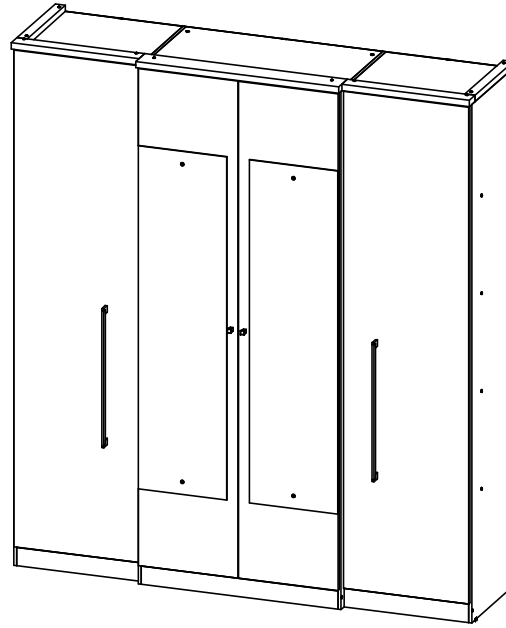

**Splendore Plus Glass**

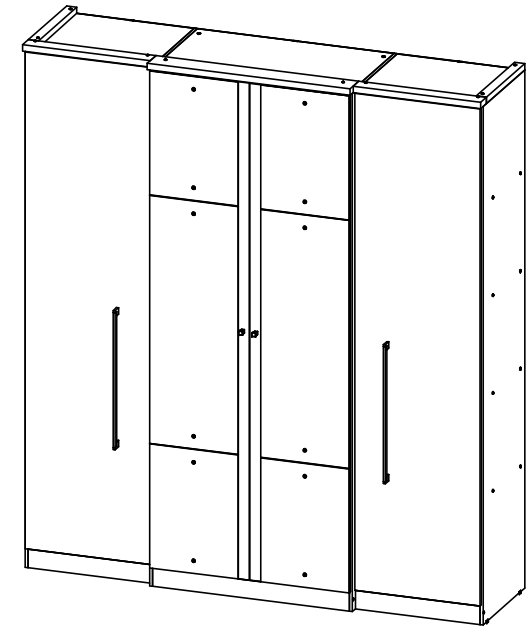

**Splendore Slim Glass**

