

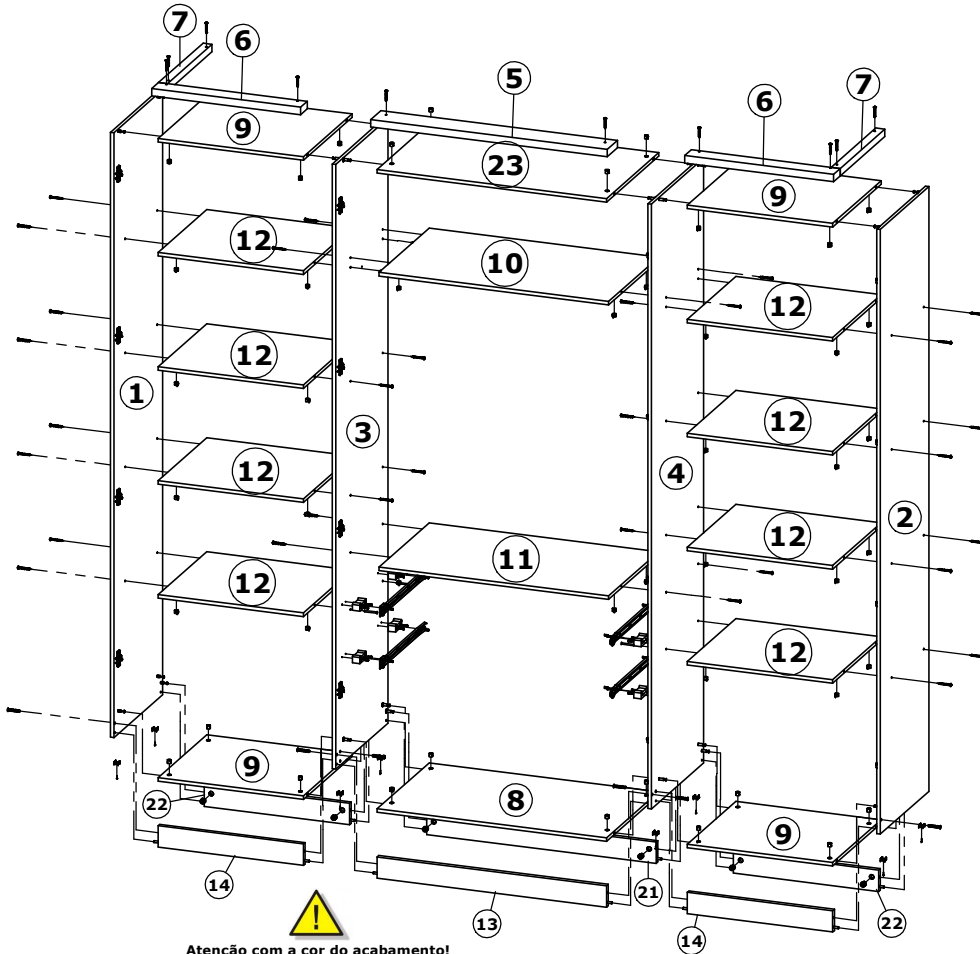

# Roupeiro Splendore 4 Portas / Wardrobe Splendore 4 Doors / Ropero Splendore 4 Puertas

quinta-feira, 11 de janeiro de 2024



Peça / Piece / Pieza	Preto / Stv	Descrição	Description	Descripción	Qtd / Qty / Cant	Compr / Length / Largo	Larg. / Width / Ancho	Esp. / Thickness / Espesor
1	P19083	Lateral Esquerda	Left Panel	Lateral Izquierda	1	2036	436	12
2	P19085	Lateral Direita	Right Panel	Lateral Derecha	1	2036	436	12
3	P19077	Divisão Esquerda	Left Division	Division Izquierda	1	2036	468	12
4	P19082	Divisão Direita	Right Division	Division Derecha	1	2036	468	12
5	P19079	Moldura Sup. Central	Central Beam Frame	Marco suprimido	1	803	92	25
6	P19081	Moldura Sup. Menor	Smallest Sup. Frame	Marco Sup. Menor	2	505	60	25
7	P19080	Moldura Sup. Lateral	Side Superstructure	Lámpara Sup. Lateral	2	401	30	25
8	P16390	Tampo Inf Central	Top Inf Central	Tapa Inf Central	1	779	468	12
9	P16387	Tampo Sup/Inf Lat.	Sup / Inf Lateral Top	Tapa Sup / Inf Lateral	4	493	436	12
10	P16384	Tampo Intermediário	Intermediate Top	Tapa	1	779	450	12
11	P16383	Tampo (1ld s/Pintura)	Cover (One ld painted)	Tapa (1ld s/ pintura)	1	779	450	12
12	P16388	Tampo Lateral	Lateral Top	Tapa lateral	8	493	436	12
13	P19078	Frente Pé Central	Front Center Foot	Frente Pie Central	1	779	72	15
14	P19084	Frente Pé Lateral	Front Side Foot	Del lado derecho	2	493	72	15
15	P16392	Frente Gaveta	Drawer Frontal	Frente del Cajón	2	723	149	12
16	P16060	Lateral Gaveta	Side Drawer	Lateral del Cajón	4	385	88	12
17	P16393	Fundo Gaveta	Bottom Drawer	Fondo del Cajón	2	704	403	2,5
18	P16391	Traseiro Gaveta	Rear Drawer	Traseo del Cajón	2	704	88	12
19	P16381	Fundo Central	Central Fund	Fondo Central	2	1964	392	2,5
20	P16382	Fundo Lateral	Lateral Background	Fondo Lateral	4	1964	249	2,5
21	P14731	Traseiro Pé Central	Rear Center Foot	Trasero Pie Central	1	779	72	15
22	P14728	Traseiro Pé Lateral	Rear Foot	Trasero Pie Lateral	2	493	72	15
23	P17543	Tampo Sup Central	Top Sup Central	Tapa Sup Central	1	779	468	12
24	P19075	Porta Lateral	Side Door	Puerta Lateral	2	1952	495	15
25	P19076	Porta Central	Central Door	Puerta Central	2	1952	394	15

### Espelhos Splendore Plus Glass

26	34849	Espelho Maior	DoorLarge Mirror	Espejo Mayor	2	974	350	3
27	34850	Espelho Menor	Small Mirror	Espejo Menor	4	487	350	3

### Espelhos Splendore Glass

27	30938	Espelho Maior	DoorLarge Mirror	Espejo Mayor	2	1348	350	3
----	-------	---------------	------------------	--------------	---	------	-----	---

Cod. Qnt.

A   10 Parafuso Biofix 33160	B   24 Parafuso 3,5x12 CP 33297	C   2 Puxador Ponto Canaan 34530 - Cromado	D   6 Parafuso Soberbão 7x40 25691	E   76 Parafuso 4,0x12 CC 30189	F   36 Parafuso 4,0x50 CF 32048 - Zincado Preto	G   4 Parafuso 4,0x50 CC 32977 - Zincado Preto	H   28 Cavilha 6x30 24603	I   2 Parafuso 3,5x25 CF 24648 (Puxador Ponto Canaan)
J   10 Parafuso 4,0x35 CF 29815	K   4 Parafuso 3,5x10 CC 36722 (Emb. c/ Sup. Cabideiro)	L   4 Parafuso 3,5x30 CF 25700 (Puxador Citrino)	M   18 Parafuso 3,5x14 CP 34125 - Zincado Branco	N   10 Paraf. Minifix Haste Dupla 30198	O   30 Presilha Fundo 24099	P   130 Prego 10x10 20179	Q   8 Sapata Plástica 12x12 38762 - Preto	R   2 Sache de cola 10g 25676
S   6 Tambor Minifix 15mm 22388	T   24 Tambor Minifix 12mm 30182	U   24 Tampa Tambor Minifix 36012 - Linho	V   4 Tampa Soberbão 38763 - Preto	W   2 Suporte Triângular 30094	X   40 Porca Cilíndrica 36008 - Linho	Y   8 Cantoneira Plástica 36010 - Linho	Z   16 Calço p/ Dobradilha 23273	AA   16 Dobradilha Baixa 23271
AB   2 Suporte Cabideiro 36611	AC   1 Adesivo Logotipo THB 31363	AD   2 Correção Macho Dir. 21611	AE   2 Correção Macho Esq. 21611	AF   2 Correção Fêmea Esq. 21611	AG   2 Correção Fêmea Dir. 21611	AH   1 Cab. Oblongo 772mm 35138	AI   3 Perfil H 1964mm 34804 - Champagne	AJ   2 Puxador Citrino 512mm 24904 - Alumínio 28717 - Ponteira Crom.
								AK   8 Distanciador 25mm 37492



**Atenção com a cor do acabamento!**  
**Em caso de assistência solicitar o código de acordo com a cor da peça /**  
**Pay attention to the color of the finish!**  
**In case of assistance request the code according to the color of the part /**  
**Atención con el color del acabado!**  
**En caso de asistencia solicitar el código de acuerdo con el color de la pieza.**



**Ferramentas necessárias (Não fornecidas)**  
**Tools Required (Not Provided)**  
**Herramientas necesarias (no incluidas)**



### Medidas em mm

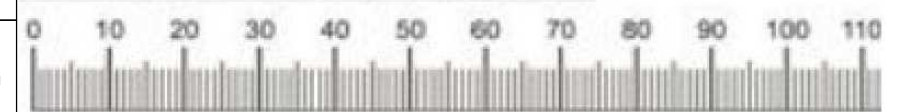

# Roupeiro Splendore 4 Portas / Wardrobe Splendore 4 Doors / Ropero Splendore 4 Puertas

## 1º Passo / Step / Paso

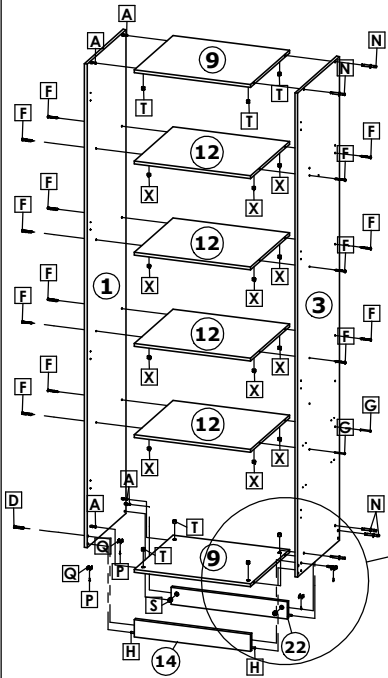

**Inicie a Montagem pelas Torres Laterais, fixando Laterais ① e ②, Divisões ③ e ④, nos Tornos ⑨ e ⑫, com Parafusos F, D, N e A/**

**Start the Assembly by the Side Towers, fixing Side ① and ②, Divisions ③ and ④, on Tops ⑨ and ⑫, with Screws F, D, N and A/**

**Inicie el Montaje por las Torres Laterales, fijando Laterales ① y ②, Divisiones ③ y ④, en los Tableros ⑨ y ⑫, con Tornillos F, D, N y A.**

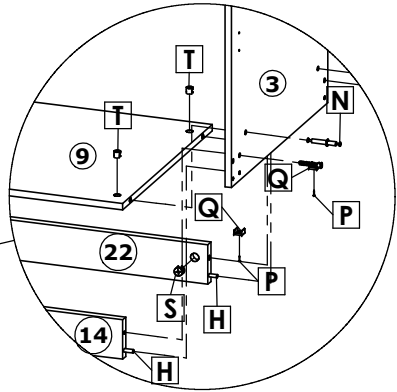

## 2º Passo / Step / Paso

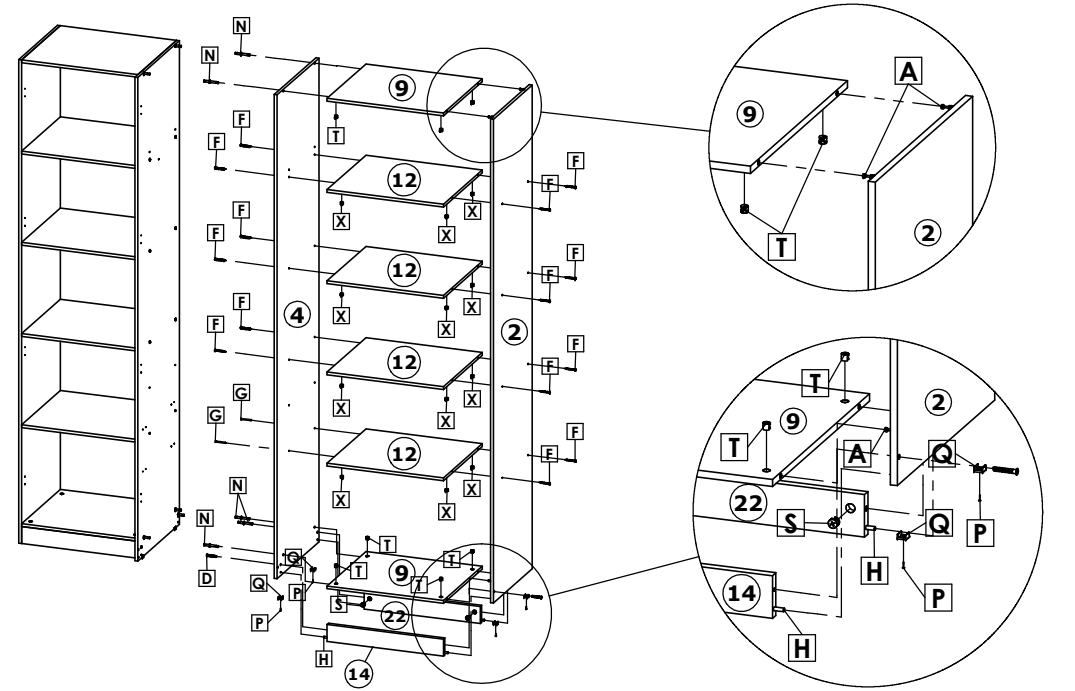

## 3º Passo / Step / Paso

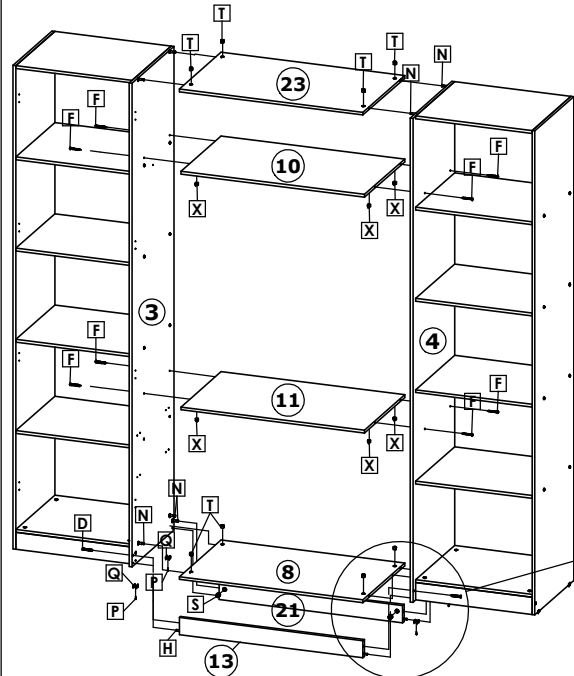

**Após a montagem das duas Torres Laterais, fixar os tornos Centrais (23), (8), (10) e (11) com Parafusos N, F e Tambor T. Já a Frente Pé (13) e Traseiro Pé (21), fixar com Parafusos D, N e Tambor S/**

**After the assembly of the two Side Towers, fix the Central tops (23), (8), (10) and (11) with Screws N, F and Drum T. Already the Front Foot (13) and Rear Foot (21), fix with Screws D, N and Drum S/**

**Después del montaje de las dos Torres Laterales, fijar las encimeras Centrales (23), (8), (10) y (11) con Tornillos N, F y Tambor T. En la parte frontal del pie (13) y trasero pie (21), fijar con tornillos D, N y tambor S.**

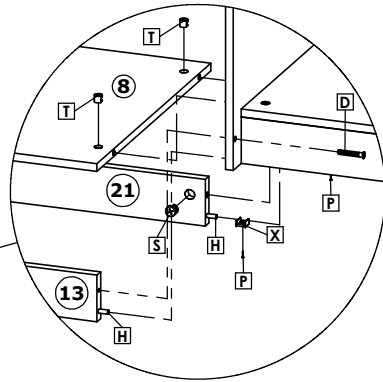

## 4º Passo / Step / Paso

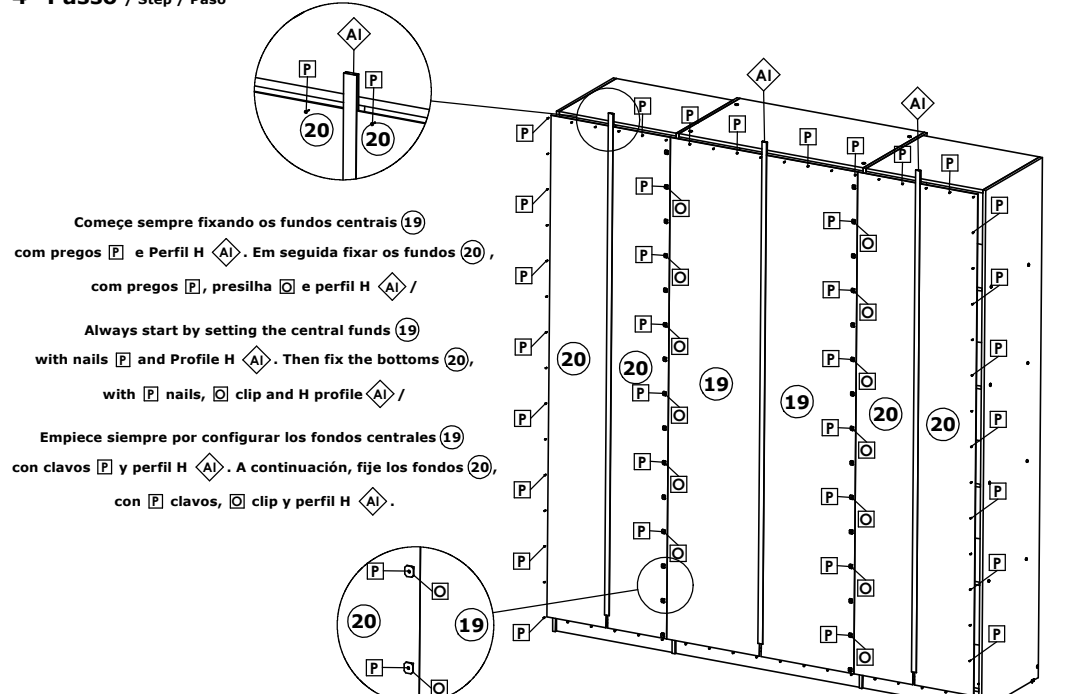

**Comece sempre fixando os fundos centrais (19) com pregos P e Perfil H (A). Em seguida fixar os fundos (20), com pregos P, presilha Q e perfil H (A) /**

**Always start by setting the central funds (19) with nails P and Profile H (A). Then fix the bottoms (20), with P nails, Q clip and H profile (A) /**

**Espiece siempre por configurar los fondos centrales (19) con clavos P y perfil H (A). A continuación, fije los fondos (20), con P clavos, Q clip y perfil H (A).**

# Roupeiro Splendore 4 Portas / Wardrobe Splendore 4 Doors / Ropero Splendore 4 Puertas

## 5º Passo / Step / Paso

Após posicionar as Molduras Superior ⑤, ⑥ e ⑦, fixa-las com Parafuso J /  
 After positioning the Top Frames ⑤, ⑥ and ⑦, secure them with Screw J /  
 Después de colocar los Marcos Superior ⑤, ⑥ y ⑦, fijarlos con Tornillo J.

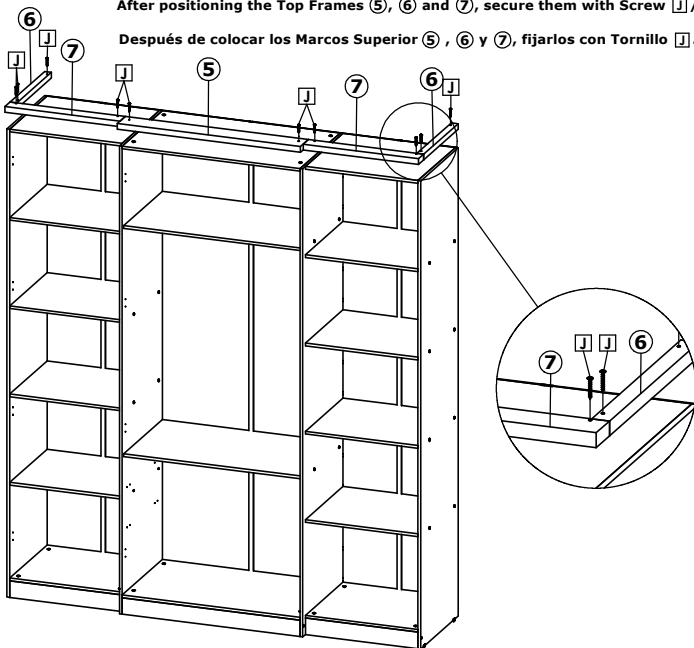

## 6º Passo / Step / Paso

### Montagem das Gavetas / Mounting the Drawers / Montaje del Cajón.

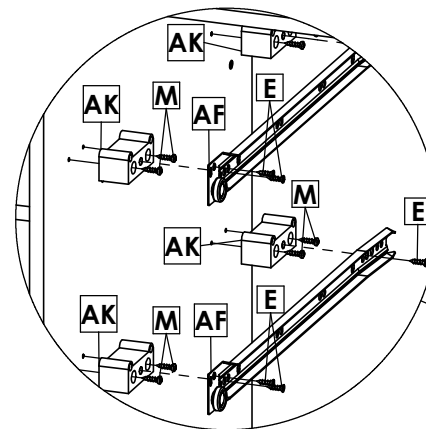
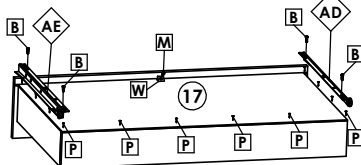
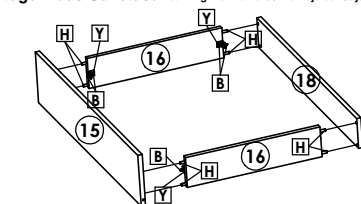

Fixar os distanciadores AK nas divisões ③ e ④, com parafusos M.  
 Logo fixar as correijas AF e AG nos distanciadores AK com parafusos E /  
 Fix spacers AK in divisions ③ and ④, with screws M.  
 Then fix the slides AF and AG on the spacers AK with screws E /  
 Fije los espaciadores AK en las divisiones ③ y ④, con tornillos M.  
 Luego fije las diapositivas AF y AG en los espaciadores AK con tornillos E.

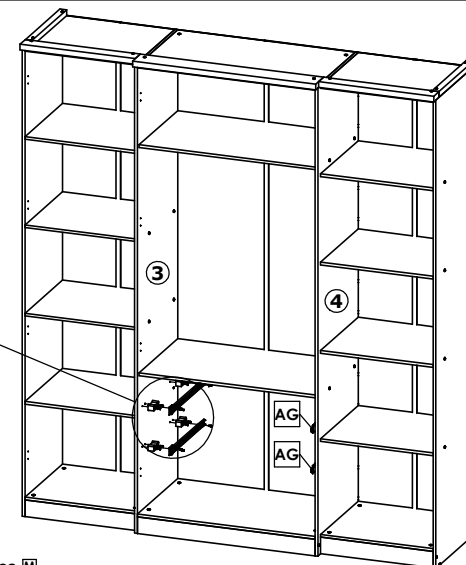

## 7º Passo / Step / Paso

### Peso Suportado / Weight supported / peso que soporta



Fixar Suportes de Cabideiro AB, com Parafuso K nas Divisões ③ e ④ /  
 Attach Clothes Rack AB with Screw K in Divisions ③ and ④ /  
 Fijar Soportes de Cabelzal AB, con Tornillo K en las Divisiones ③ y ④.

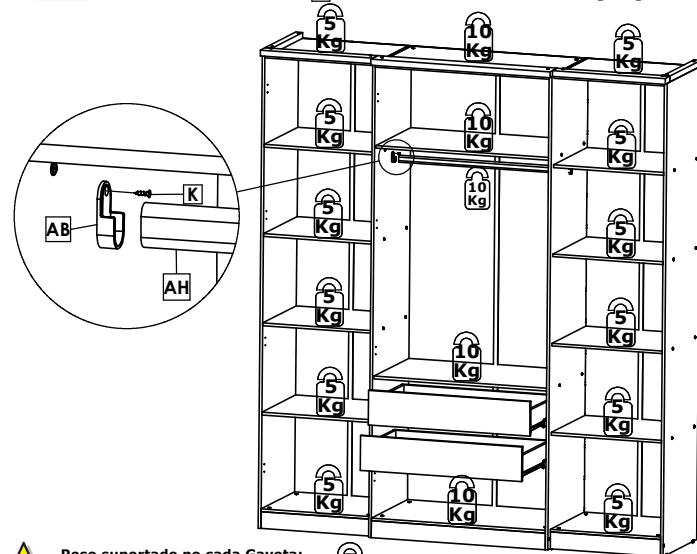

Peso suportado po cada Gaveta:  
 Weight supported by each Drawer:  
 Peso suportado por cada Cajón: 5 Kg

## Montagem Portas Splendore / Splendore Doors / Puertas Splendore

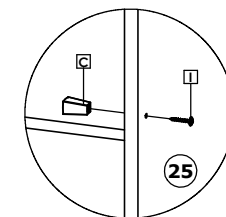
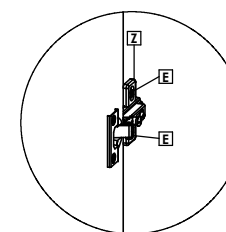
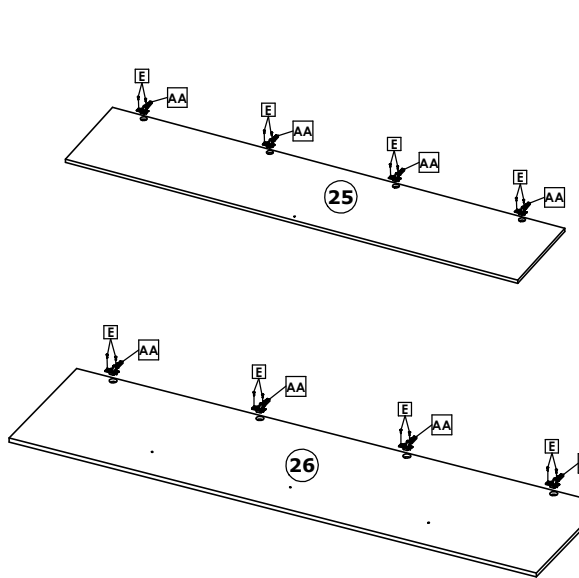

Fixar Puxador C, com Parafuso I /  
 Attach Knob C, with Screw I /  
 Fijación Tirador C, con Tornillo I.

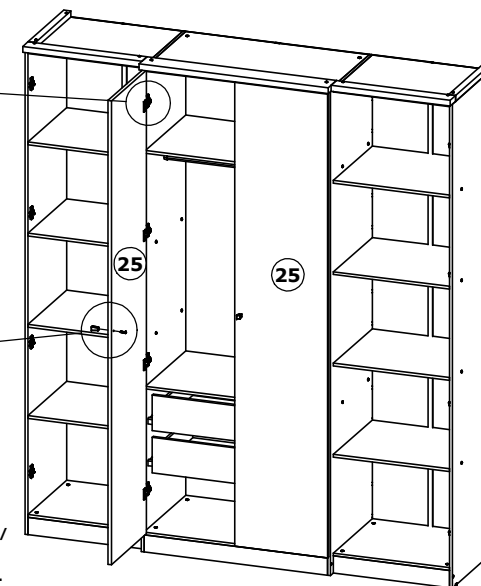

# Roupeiro Splendore 4 Portas / Wardrobe Splendore 4 Doors / Ropero Splendore 4 Puertas

## Montagem Portas Splendore/ Splendore Doors / Puertas Splendore

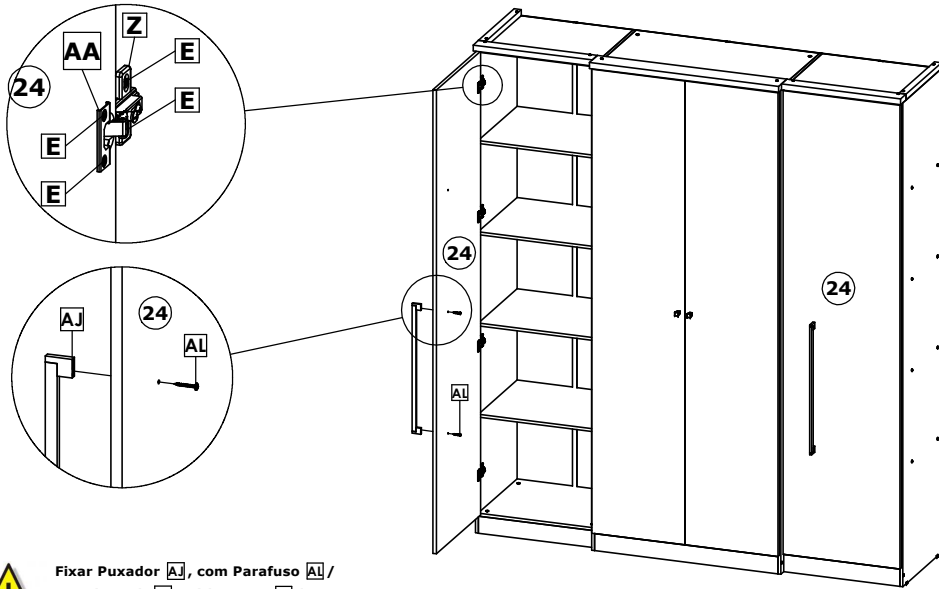

Fixar Puxador **AJ**, com Parafuso **AL** /  
 Attach Knob **AJ**, with Screw **AL** /  
 Fijación Tirador **AJ**, con Tornillo **AL**.

Inicie a montagem alinhando os Espelhos Superior **(27)**, com a Lateral e topo da Porta **(25)**.

Logo inserir os Espelhos **(26)** e **(27)**, fixando-os com Parafusos **AM** e Suporte Vidro Pino **AL**, deixando entre cada Espelho um espaçamento de 2mm /  
 Start the assembly by aligning the Top **(27)**, Mirrors with the Side and Top of Door **(25)**.

Then insert Mirrors **(26)** and **(27)**, securing them with Screws **AM** and Glass Pin Support **AL**, leaving between each Mirror a spacing of 2mm /

Inicie el montaje alineando los espejos **(27)** superior, con el lateral y la parte superior de la puerta **(25)**.

Luego inserte los Espejos **(26)** y **(27)**, fijándolos con Tornillos **AM** y Soporte Vidro Pino **AL**, dejando entre cada espejo un espaciamento de 2mm.

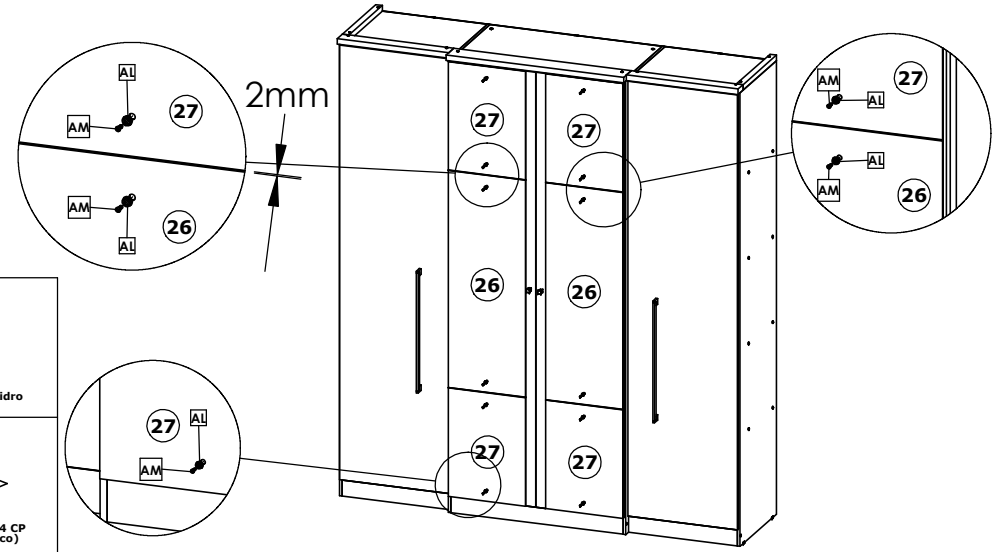

Posicione os Espelhos **(26)**, á 302mm do Topo da Porta **(25)** e paralelo a lateral da Porta **(25)**.

Logo fixe os Espelhos **(26)**, com Parafusos **AM** e Suporte Vidro Pino **AM** /

Position Mirrors **(26)**, 302mm from Top of Door **(25)** and parallel to side of Door **(25)**.

Then secure the Mirrors **(26)**, with Screws **AM** and Mount Glass Pin **AM** /

Coloque los espejos **(26)**, a 302mm de la parte superior de la puerta **(25)** y paralelo al lateral de la puerta **(25)**.

Luego fije los Espejos **(26)**, con Tornillos **AM** y Soporte Vidro Pino **AM**.

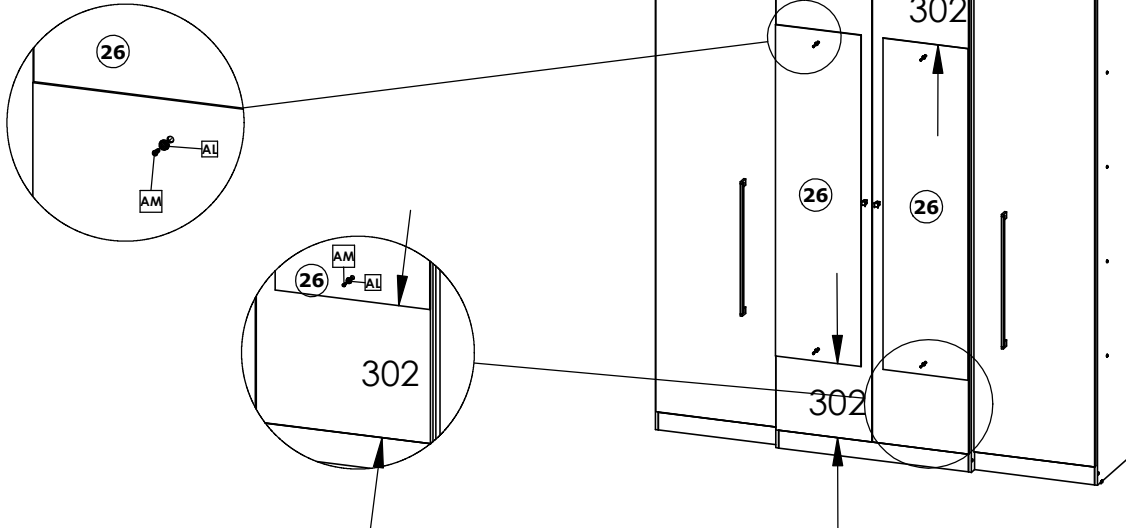

## Splendore

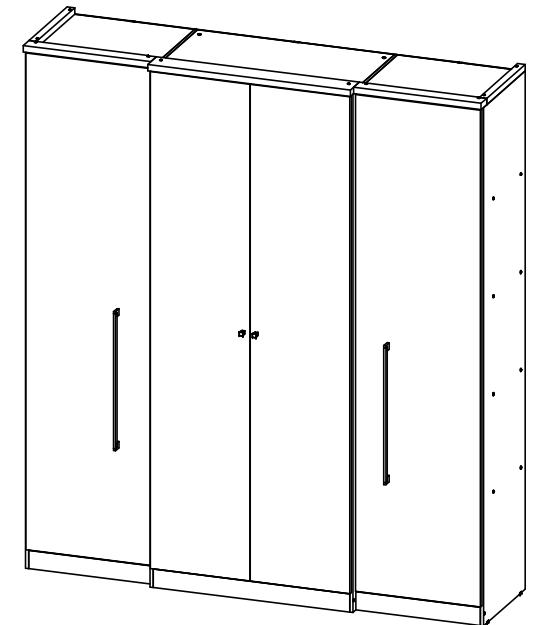

**Roupeiro Splendore 4 Portas / Wardrobe Splendore 4 Doors / Ropero Splendore 4 Puertas**

**Splendore Glass**

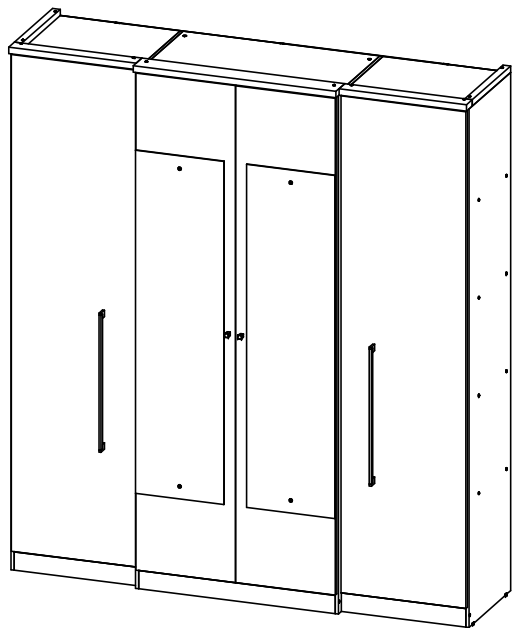

**Splendore**

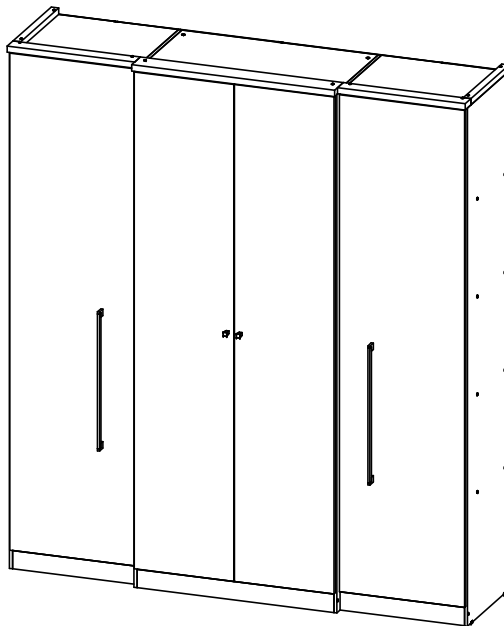

**Splendore Plus Glass**

