

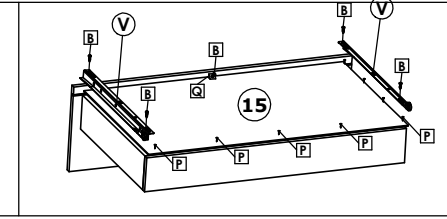

# Roupeiro Prisma Plus 4P / Wardrobe Prisma Plus 4P/ Ropero Prisma Plus 4P

quarta-feira, 28 de junho de 2023

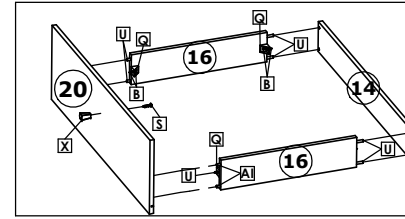
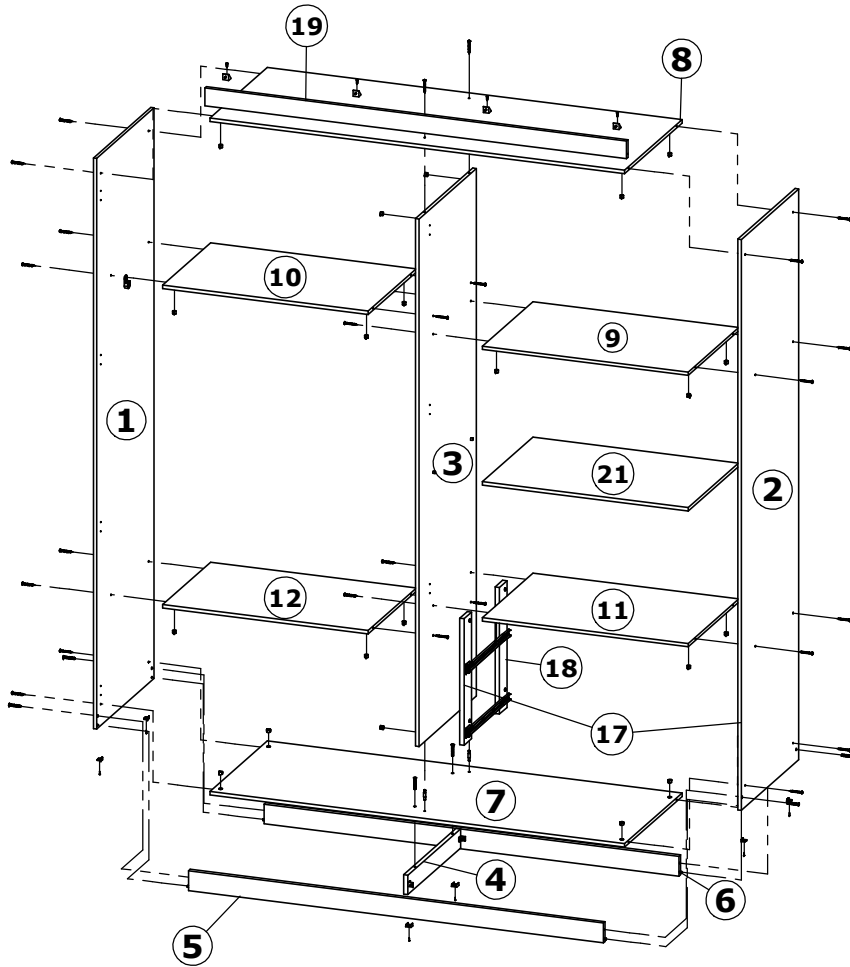

## Roupeiro Prisma Plus 4P Capuccino c| Linho

Peça Pieze Pieza	Cod.	Descrição	Description	Descripción	Qtde Qty Cant	Compr Lenght Largo	Larg. Widht Ancho	Esp. Tickness Espesor
1	P19605	Lateral Esq.	Left Side Panel	Lateral Izquierda	1	2002	536	12
2	P19608	Lateral Dir.	Right Side Panel	Lateral Derecha	1	2002	536	12
3	P19606	Divisão	Division	División	1	1850	536	12
4	P13930	Divisão Pé	Division Foot	Pie división	1	492	68	15
5	P19610	Frente Pé	Frontal Botton Frame	Zocalo Frontal	1	1466	69,5	15
6	P14947	Traseiro Pé	Back Botton Frame	Zocalo Traseiro	1	1466	69,5	15
7	P19613	Tampo Inferior	Surface Bottom	Superficie inferior	1	1466	536	12
8	P19609	Tampo Superior	Table Top	Table Top	1	1466	536	12
9	P17625	Tampo Int. Maior	Top int. Bigger	Top Int. Más	1	727	472	12
10	P17624	Tampo Int. Menor	Top int. Smaller	Top Int. Menos	1	727	450	12
11	P19607	Tampo Gav. 1 ld s/ Pint.	Top drawer 1 s hand / Painting	Top Cajón s mano / Pintura	1	727	472	12
12	P17617	Tampo ( 1ld s/ Pint)	Top (1ld s / Pint)	Tapa (1ld s / Pint)	1	727	450	12
13	P17608	Fundo	Background	Fondo	2	1875	740	2,5
14	P17627	Traseiro Gaveta	Drawer Back	Traseiro Cajón	2	673	88	12
15	P17623	Fundo Gaveta	Drawer Back	Fondo Cajón	2	672	402	2,5
16	P16060	Lateral Gaveta	Drawer Side	Lateral Cajón	4	385	88	12
17	P19612	Distanciador	Spacer	Spacer	2	444	70	15
18	P15007	Distanciador s/ Pint.	Spacer s/ Pint.	Spacer s/ Pint.	2	444	70	15
19	P19611	Moldura Superior	Frame Superior	Enmarcar Superior	1	1490	62	15
20	P19585	Frente Gaveta	Drawer Front	Frente del Cajón	2	716	219	12
21	P17626	Prateleira	Shelf	Estante	1	727	472	12
22	P19579	Porta Menor	Door Smaller	Puerta Menos	2	1393	359	12
23	P19581	Porta Maior	Door Bigger	Puerta Más	2	1892	368	12

Cod. Qnt.

A 4	B 40	C 2	D 2	E 8	F 4	G 2	H 56	I 6
Parafuso 3,5x10 CC (P/ Suporte Cabideiro) 36722	Parafuso 3,5x12 CP 33297	Parafuso Minifix 25679	Tambor Minifix 30182	Paraf. Correção 6x12 22396	Parafuso 3,0x10 CC 33199	Suporte Cabideiro 36611	Parafuso 4,0x12 CC 30189	Parafuso Soberbão 7x40 PH 10 25691
J 14	K 8	L 6	M 14	N 6	O 13	P 95	Q 12	R 2
Calço p/ Dobradça 23273	Dobradça Baixa 23271	Dobradça Alta 23272	Calço Plástico Dobradça 39352 - Preto	Tampa Soberbão 31078 - Capuccino	Presilha Fundo 24099	Prego 10x10 CC 20179	Cantoneira 20x20x20 37090	Cantoneira Plástica 36010
S 14	T 1	U 20	V 2	W 2	X 6	Y 1	Z 1	AA 2
Parafuso 3,5x25 CF 24648	Parafuso 4,0x45 CC 33696 - Zincado Amarelo	Cavilha 6x30 24603	Kit Correção 400mm 21611	Tapa Furo 5mm 36009	Puxador Ponto Bronze 34842	Cab. Oblongo 719mm 36929	Sachê de Cola 25676	Suporte Triangular 30094
AB 2	AC 4	AD 1	AE 25	AF 26	AG 4	AH 2	- -	- -
Tampa Tambor 36012	Suporte Prateleira 36013	Adesivo Logotipo THB 31363	Parafuso 4,0x45 CF 33292 - Zincado Amarelo	Porca Cilíndrica 33195 - Linho 34524 - Capuccino	Sapata Plástica L 34444 - Capuccino	Sapata Plástica U 31077 - Capuccino	- -	- -



**Atenção com a cor do acabamento!**  
Em caso de assistência solicitar o código de acordo com a cor da peça.

Medidas em mm



# Roupeiro Prisma Plus 4P / Wardrobe Prisma Plus 4P/ Ropero Prisma Plus 4P

## 1º Passo / Step / Paso

Fixar Divisão Pé ④ no Tampo Inferior ⑦ com Parafusos Soberbão ①. Logo fixar com Cantoneira ② e Parafuso ③ a Frente e Traseiro pé ⑤ e ⑥ nas Divisões Pé ④.

Division set foot ④ in Lower Surface ⑦ with screws Soberbão ①. Once set to ② bracket screw ③ and the Front and Rear foot ⑤ and ⑥ in Divisions ④.

Divisone puesto un pie en la Baja ④ Superficie ⑦ con tornillos Soberbão ①. Una vez que ponen a ② soporte de la hélice ③ y la parte delantera y trasera del pie ⑤ y ⑥ en las Divisiones ④.

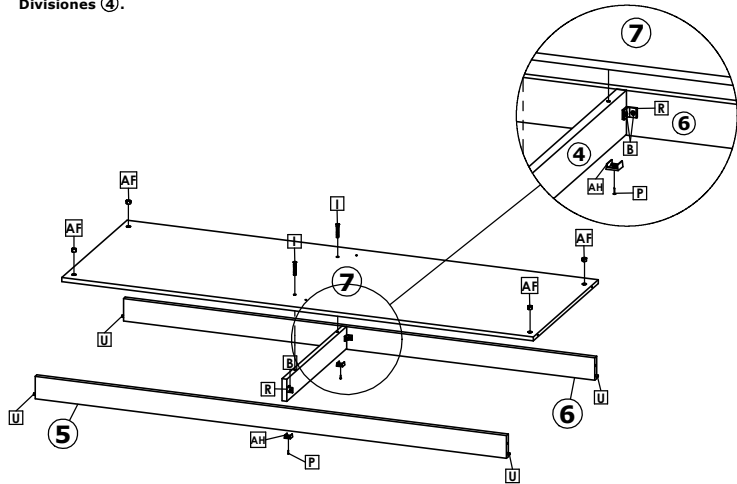

## 2º Passo / Step / Paso

Fixar Laterais ①, ② e Divisão ③ no Tampo Inferior ⑦, com Parafusos ④E, ①, ③ e Tambor ④. Em seguida fixar Tamos ⑨, ⑩, ⑪ e ⑫, com Parafusos ④E e Porca Cilindrica ④F.

Attach Sides ①, ②, and Division ③ on Bottom Top ⑦, with Screws ④E, ①, ③ and Drum ④. Then fix Tampons ⑨, ⑩, ⑪ and ⑫ with Screws ④E and Nut Cylindrica ④F.

Fijación Laterales ①, ② y División ③ en el Tablero Inferior ⑦, con Tornillos ④E, ①, ③ y Tambor ④. A continuación, fijar los Tapones ⑨, ⑩, ⑪ y ⑫, con Tornillos ④E y Tuerca Cilindrica ④F.

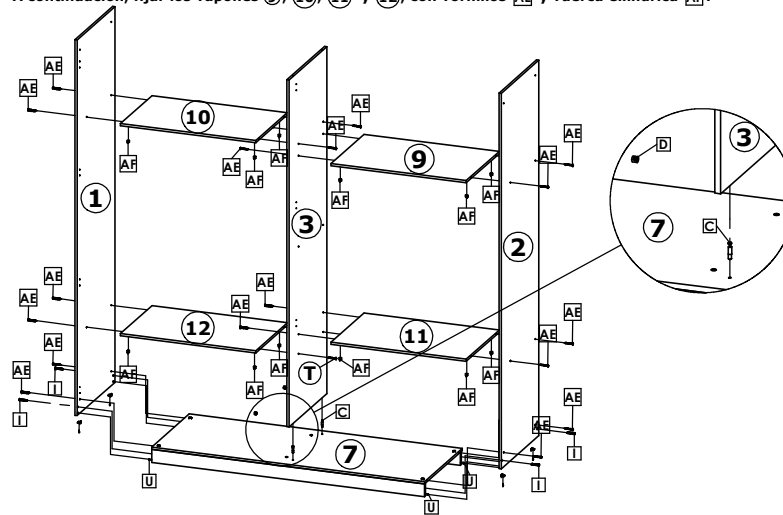

## 3º Passo / Step / Paso

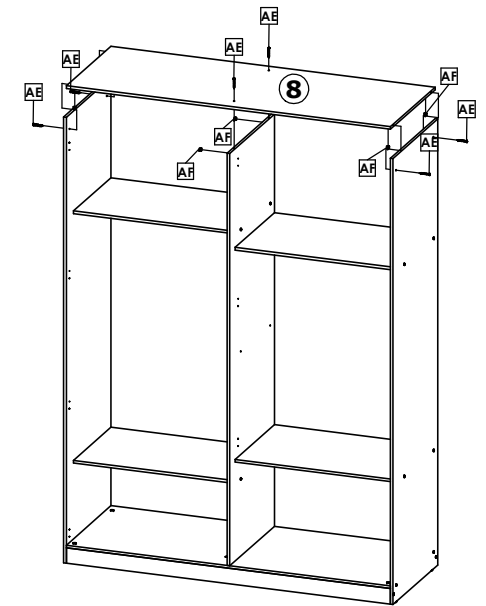

## 4º Passo / Step / Paso

Fixar Fundos ⑬, com Pregos ①P e Presilhas ①Q.

Attach Funds ⑬, with Nails ①P and Clips ①Q.

Fijar Fondos ⑬, con clavos ①P y sujetadores ①Q.

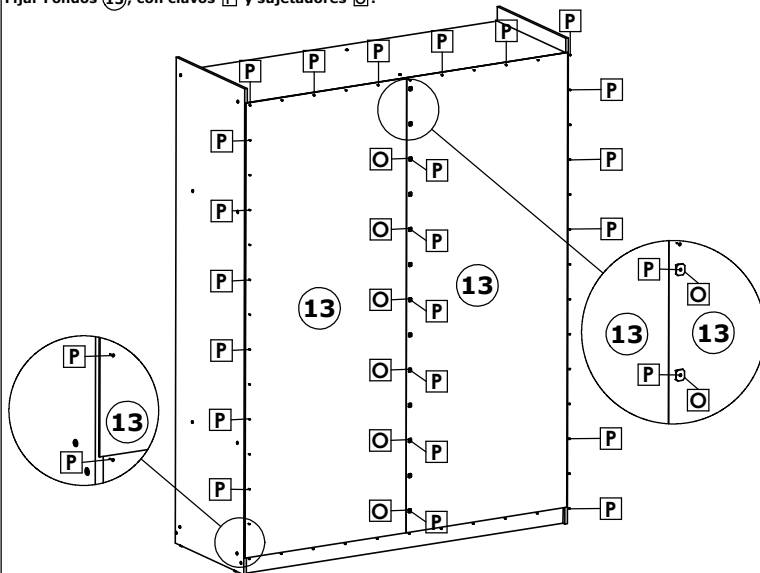

## 5º Passo / Step / Paso

Fixar as molduras ⑲ com cantoneira ①Q e parafusos ①B.

Fix the frames ⑲ with angle bracket ①Q and screws ①B.

Fix the frames ⑲ with angle bracket ①Q and screws ①B.

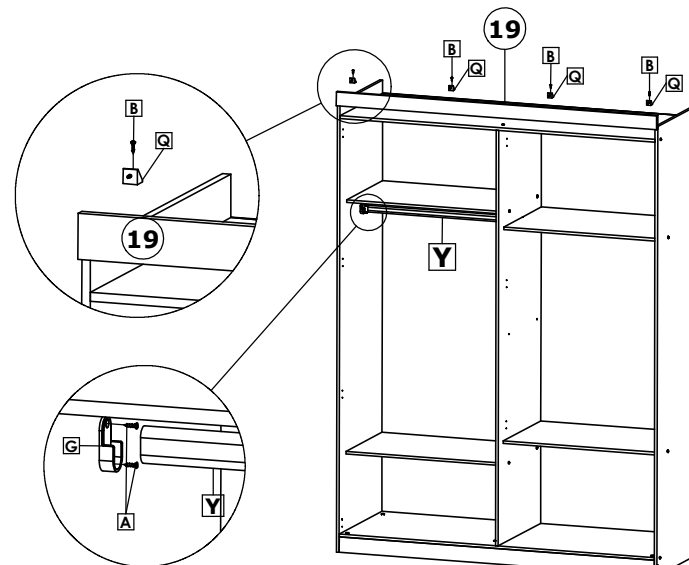

## 6º Passo / Step / Paso

Posicionar o Distanciador ⑰ paralelo ao Tampo ①①.

Position Spacer ⑰ parallel to Top ①①.

Posicionar el Distanciador ⑰ paralelo al Tablero ①①.

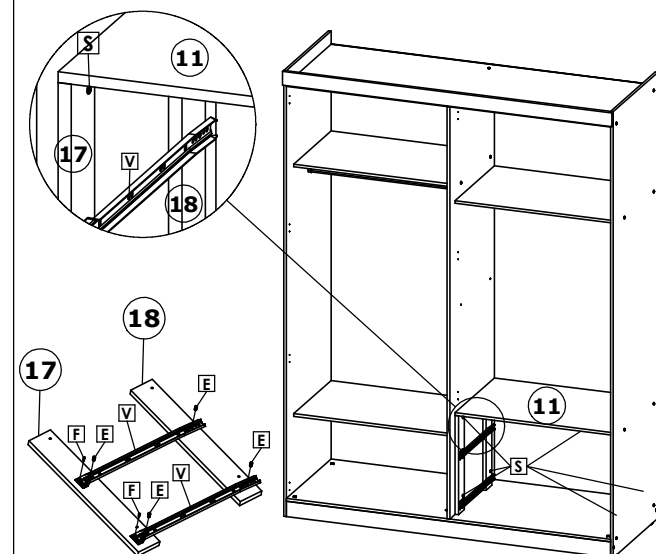

# Roupeiro Prisma Plus 4P / Wardrobe Prisma Plus 4P/ Ropero Prisma Plus 4P

## 7º Passo / Step / Paso

Faça o encaixe dos Suportes de Prateleiras e das Gavetas, conforme ilustrado abaixo.  
Attach the Shelf Brackets and Drawers, as shown below.  
Haga el acoplamiento de los soportes de estantes y de los cajones, como se muestra a continuación.

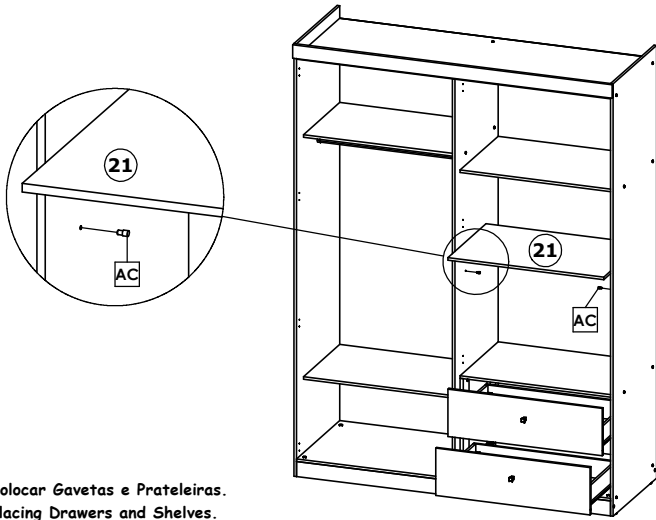

Colocar Gavetas e Prateleiras.  
Placing Drawers and Shelves.  
Colocar Gavetas y Estantes.

## 8º Passo / Step / Paso

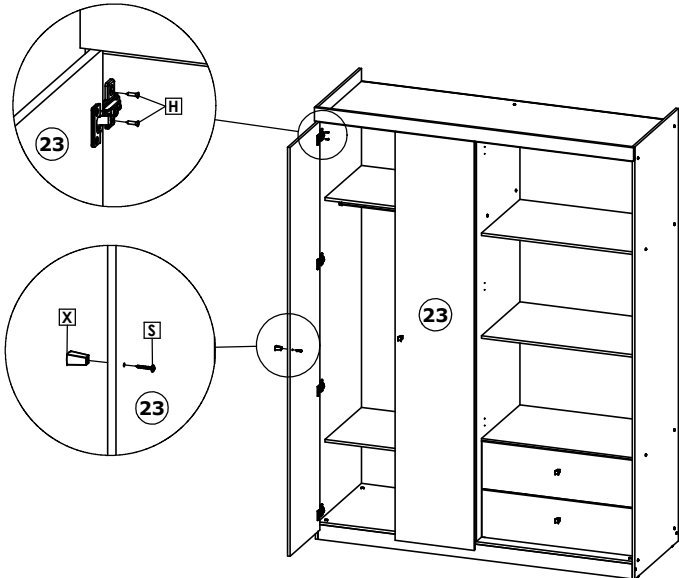

Fixar Puxador X nas Portas (23), com Parafuso S.  
Attach Knob X on Doors (23), with Screw S.  
Fijación Tirador X en las Puertas (23), con Tornillo S.

## Peso Suportado / Weight supported / peso que soporta

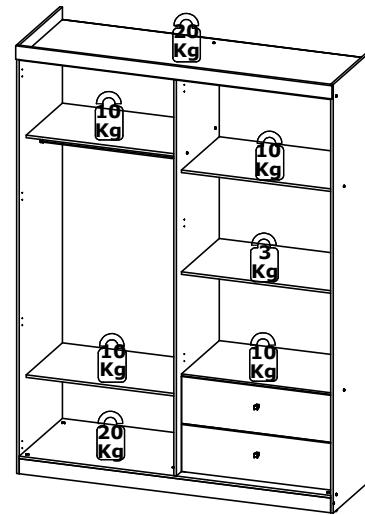

Peso Suportado por cada gaveta. 5 Kg  
Weight Supported per drawer.  
Peso soportado por cada cajón.

## 9º Passo / Step / Paso

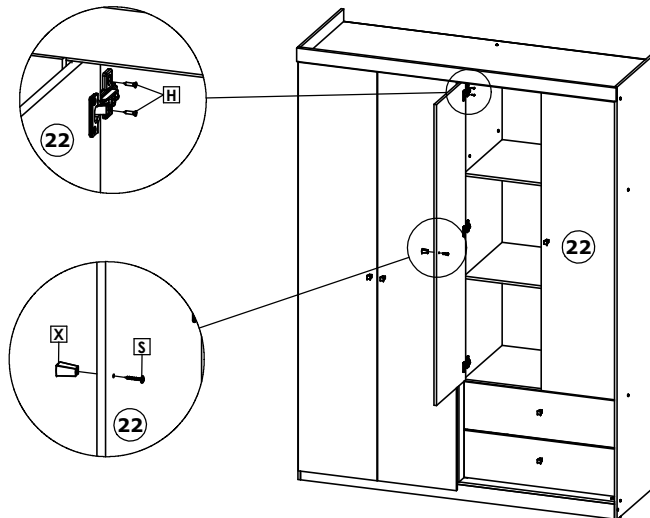

Fixar Puxador X nas Portas (22), com Parafuso S.  
Attach Knob X on Doors (22), with Screw S.  
Fijación Tirador X en las Puertas (22), con Tornillo S.

## Montagem das Portas / Mounting the Doors/ Montaje de las Puertas

Usar Dobradiça Alta L, calço plástico M, calço J e Parafuso H nas Portas (22).  
Use High Hinge L, plastic shim M, shim J and Screw H on Doors (22).  
Utilice la bisagra alta L, la cuña de plástico M, la cuña J y el tornillo H en las puertas (22).

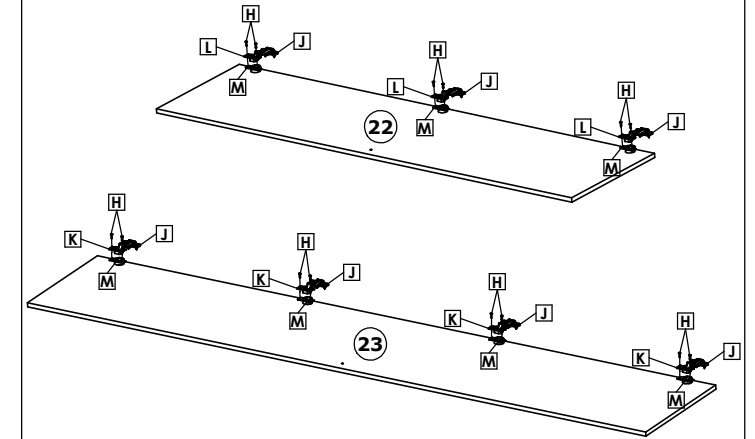

Usar Dobradiça baixa K, calço plástico M, calço J e Parafuso H nas Portas (23).  
Use low hinge K, plastic shim M, shim J and Screw H on Doors (23).  
Usar bisagra baja K, la cuña de plástico M, la cuña J y el tornillo H en las puertas (23).

## Prisma Plus

