

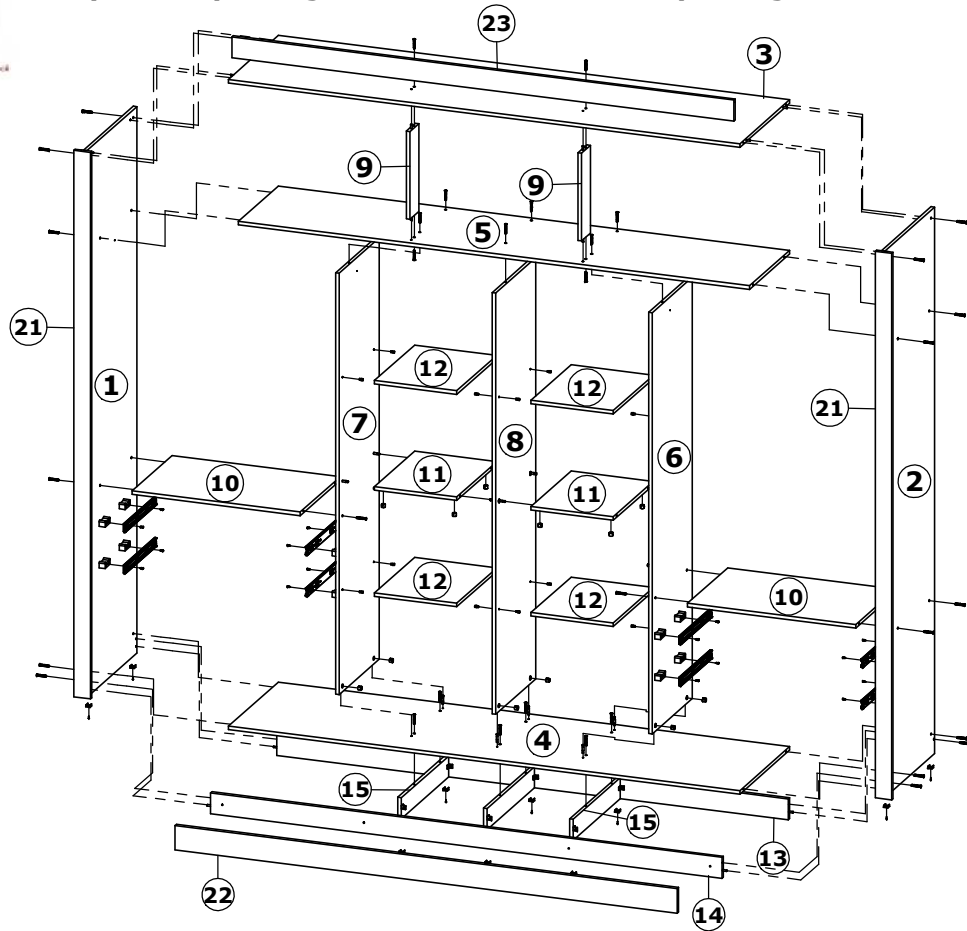

Folhas especificamente por peça



Cod. Qnt.

A 8 Parafuso 3,5x12 CC 36723 (Para Sup. Cabideiro)	B 198 Parafuso 3,5x12 CP 33297	C 31 Parafuso 4,0x14 CC 37705 - Zinc. Branco	D 40 Paraf. Soberbão 7x40 25691	E 10 Parafuso Minifix 25679	F 2 Parafuso Minifix Haste Dupla 25675	G 14 Tambor Minifix 22388	H 4 Parafuso 3,5x25 CF 34632 - Zinc. Branco	I 44 Cavilha 6x30 24603
J 155 Prego 10x10 20179	K 54 Presilha Fundo 24099	L 4 Cantoneira 20x20x20 37067 - Cap	M 22 Cantoneira Plástica 31075 - Cap	N 6 Cantoneira 20x20x42 31074 - Cap	O 24 Parafuso 3,5x12 CF 25683 - Zinc. Branco	P 4 Suporte Triângular 30094	Q 4 Suporte Cabideiro 36611	R 10 Sapata Plástica (02.02.013) 31077 - Cap
S 16 Suporte Prateleira 36724 - Cap	T 2 Sache de cola 10g 36724	U 30 Tampa Soberbão 39475 - Cap	V 14 Tampa Tambor 33924 - Cap	W 2 Chapa Junção Moldura 34812 - Aço	X 64 Parafuso 3,0x10 CC 33199 - Zinc. Branco	Y 16 Chapa Junção Porta 37492	Z 16 Distanciador 25mm 35690	AA 2 Cab. Oblongo 704mm 31363
AB 4 Trilho Telescópico 36952	AC 2 Perfil H 2190mm 39475 - Cap	AD 3 Perfil I 381mm 39481 - Alumínio	AE 1 Trilho Inf. 2167x46mm 39481 - Alumínio	AF 1 Perfil E 2167x70mm 39388 - Plástico	AG 4 Cantoneira Especial U (2129mm) 39390 - Bronze	AH 1 Pux. Titanium 160mm 35986 - Bronze	AI 14 Parafuso 4,0x22 CF (Puxador Ibiza) 39085	AJ 1 Adesivo Logo THB 31363
AK 6 Guia Folha Zero 35766	AL 6 Rodízio Inferior 35766	AM 36 Parafuso 3,5x20 CF 25683 - Zincado Branco	AN 6 Trava da Porta 35766	AO 18 Parafuso 3,5x20 CC 30519	AP 6 Parafuso 3,5x14 CP 34125 - Zinc. Branco	AQ 6 Suporte Vidro 25678	AR 8 Parafuso 3,5x14 CP 34125 - Zinc. Branco	AS 8 Suporte Vidro 25678

Kit Sistema Correr cod. 35766

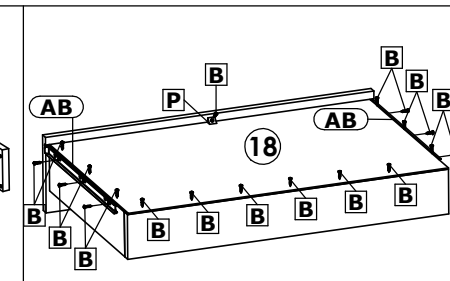
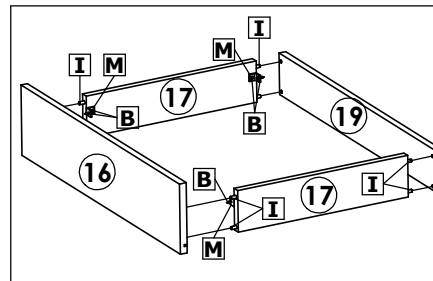

Roupeiro Copenhagen|Ibiza Capuccino

Peça / Piece / Pieza	Cod.	Descrição	Description	Descripción	Qtde Qty Cant	Compr Length Largo	Larg. Width Ancho	Esp. Thickness Espesor
1	P19624	Lateral Esquerda	Left Panel	Lateral Izquierda	1	2300	560	15
2	P19625	Lateral Direita	Right Panel	Lateral Derecha	1	2300	560	15
3	P19630	Tampos Superior	Top	Tapa Superior	1	2169	560	15
4	P19629	Tampo Inferior	Top	Tapa Inferior	1	2169	560	15
5	P19631	Tampo Intermediário	Intermediate Top	Tapa Intermediaria	1	2169	450	15
6	P19627	Divisão Dir	Right Side Division	Division Der	1	1773	450	15
7	P19626	Divisão Esq	Left Side Division	Division Izq	1	1773	450	15
8	P19628	Divisão Central	Central Division	Division Central	1	1773	450	15
9	P19643	Divisão Maleiro	Division	Division	2	369	100	15
10	P19632	Tampo Sup. Gaveta	Top Drawer Higher	Tapa Superior Cajón	2	713	450	15
11	P19633	Tampo Menor	Small Top	Top pequeno	2	349	450	15
12	P19634	Prateleira	Shelf	Repisa	4	349	450	15
13	P19636	Traseiro Pé	Back Bottom Frame	Zocalo Traseiro	1	2169	88	15
14	P19635	Frete Pé	Bottom Frame	Marco Inferior	1	2169	88	15
15	P19639	Divisão Pé	Division Bottom Frame	Division Zocalo	3	529	88	15
16	P19639	Frete Gaveta	Drawer Frontal	Frete del Cajón	4	652	149	15
17	P19734	Lateral Gaveta	Side Drawer	Lat del Cajón	8	385	88	15
18	P19641	Fundo Gaveta	Bottom Drawer	Fondo del Cajón	4	636	406	2,5
19	P19640	Traseiro Gaveta	Rear Drawer	Traseo del Cajón	4	638	88	15
20	P19642	Fundo	Back Panel	Fondo	6	2190	363	2,5
21	P19650	Moldura Lateral	Side Frame	Marco Lateral	2	2300	70	15
22	P19649	Moldura Inferior	Inferior Frame	Marco Inferior	1	2129	103	15
23	P19648	Moldura Superior	Top Frame	Marco Superior	1	2129	88	15

Roupeiro Copenhagen 2P Reversível Capuccino|Off White c| Cacau

24	P19622	Porta Sup. Reversível	Upper Door	Puerta Superior	2	1052	1092	15
25	P19623	Porta Inf. Reversível	Lower Door	Puerta inferior	2	865	1092	15
26	P19730	Aplique Maior	Apply Greater	Aplique Mayor	2	852	212	9
27	P19731	Aplique Menor	Apply Minor	Aplique Menor	2	155	212	9
28	34749	Espelho	Mirror	Espejo	2	250	105	3

Roupeiro Copenhagen 2P Capuccino c| Menta

24	P19728	Porta Sup.	Upper Door	Puerta Superior	2	1052	1092	15
25	P19729	Porta Inf.	Lower Door	Puerta inferior	2	865	1092	15
26	P19730	Aplique Maior	Apply Greater	Aplique Mayor	2	852	212	9
27	P19731	Aplique Menor	Apply Minor	Aplique Menor	2	155	212	9
28	34749	Espelho	Mirror	Espejo	2	250	105	3

Espelhos Roupeiro Copenhagen

29	37823	Espelho Maior	Larger Mirror	Espejo más Grande	3	668	350	3
----	-------	---------------	---------------	-------------------	---	-----	-----	---

Roupeiro Ibiza 3P Reversível Capuccino|Off White c| Cacau

30	P19721	Porta Lat. Reversível	Side door	Puerta Lateral	2	2129	736	15
31	P19621	Porta Central	Central Door	Puerta Central	2	2129	736	15
32	P19722	Moldura Porta	Door Frame	Marco Puerta	2	2124	70	9

Roupeiro Ibiza 3P Capuccino c| Menta

30	P19620	Porta Lat.	Side door	Puerta Lateral	2	2129	736	15
31	P19621	Porta Central	Central Door	Puerta Central	2	2129	736	15
32	P19722	Moldura Porta	Door Frame	Marco Puerta	2	2124	70	9

Espelhos Roupeiro Ibiza

33	37363	Espelho	Mirror	Espejo	4	600	451	3
----	-------	---------	--------	--------	---	-----	-----	---

Medidas em mm

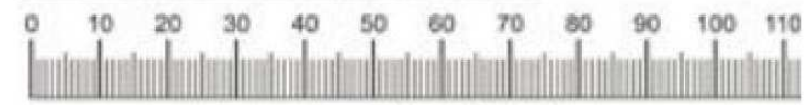

Roupeiro Copenhagen | Ibiza | Wardrobe Copenhagen | Ibiza | Armario Copenhagen | Ibiza.

1º Passo / Step / Paso

Inicie a montagem da base, fixando o tampo ④ nas divisões pé ⑮, com parafusos ①.
 Start assembling the base, fixing the worktop ④ to the divisions foot ⑮, with screws ①.
 Comience a ensamblar la base, fijando la parte superior ④ en las divisiones de pies ⑮, con tornillos ①.

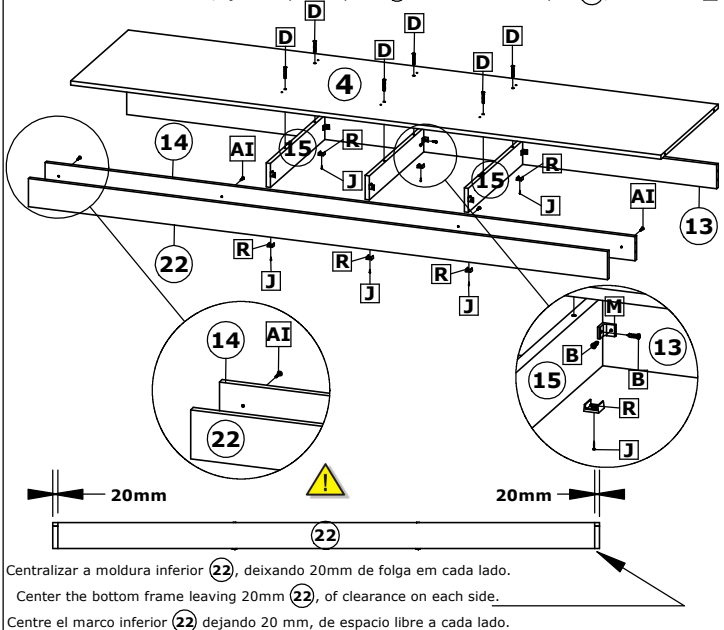

Centralizar a moldura inferior ②②, deixando 20mm de folga em cada lado.
 Center the bottom frame leaving 20mm ②②, of clearance on each side.
 Centre el marco inferior ②② dejando 20 mm, de espacio libre a cada lado.

2º Passo / Step / Paso

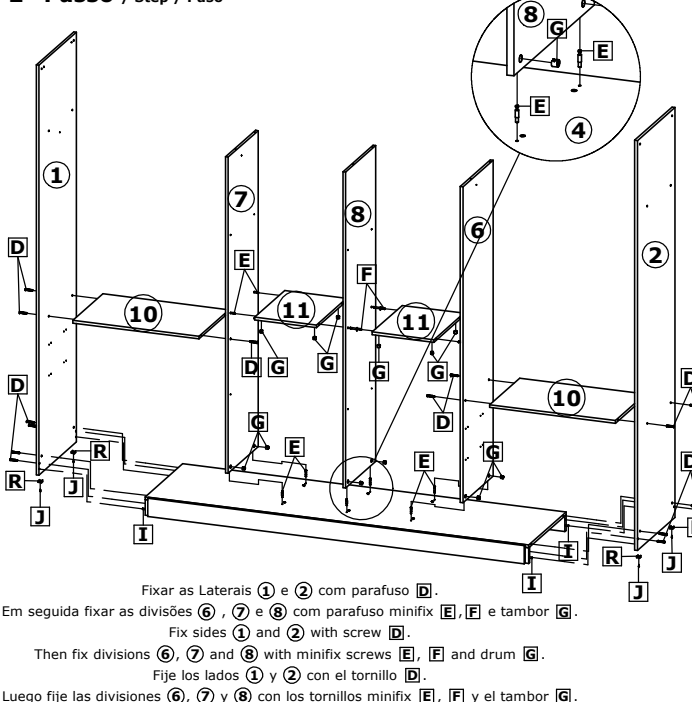

Fixar as Laterais ① e ② com parafuso ①.
 Em seguida fixar as divisões ⑥, ⑦ e ⑧ com parafuso minifix ⑤, ⑥ e tambor ⑦.
 Fix sides ① and ② with screw ①.
 Then fix divisions ⑥, ⑦ and ⑧ with minifix screws ⑤, ⑥ and drum ⑦.
 Fije los lados ① y ② con el tornillo ①.
 Luego fije las divisiones ⑥, ⑦ y ⑧ con los tornillos minifix ⑤, ⑥ y el tambor ⑦.

3º Passo / Step / Paso

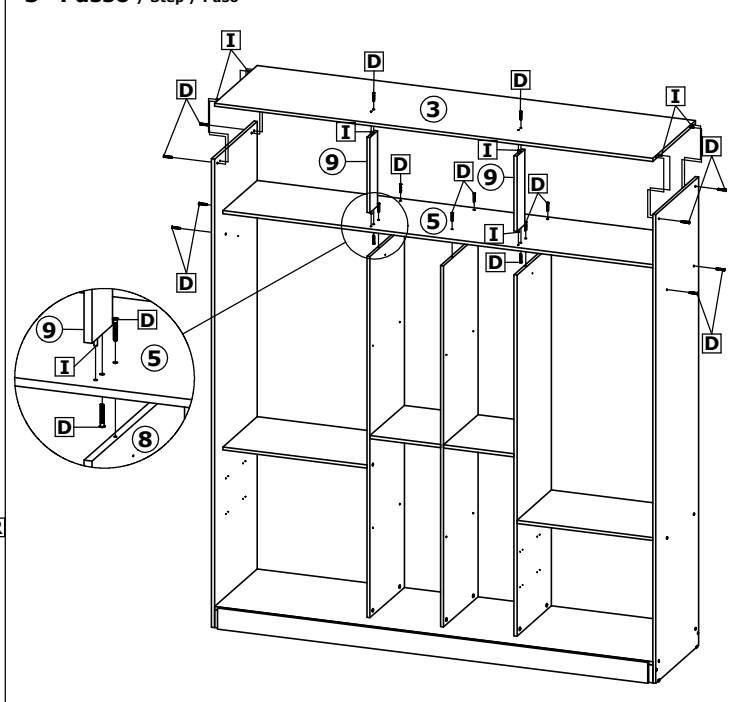

Centralizar a moldura superior ②③, deixando 20mm de folga em cada lado.
 Faça a união das molduras ②③ e ②① com chapinha ②④ e parafuso ②⑤.
 Center top frame ②③, leaving 20mm of clearance on each side.
 Join frames ②③ and ②① with a straightener ②④ and screw ②⑤.
 Centre el marco superior ②③, dejando 20 mm de espacio libre a cada lado.
 Unir los marcos ②③ y ②① on una plancha ②④ y un tornillo ②⑤.

4º Passo / Step / Paso

O espaço entre um prego e outro é de 100mm.
 The space between one nail and another is 100mm.
 El espacio entre un clavo y otro es de 100 mm.

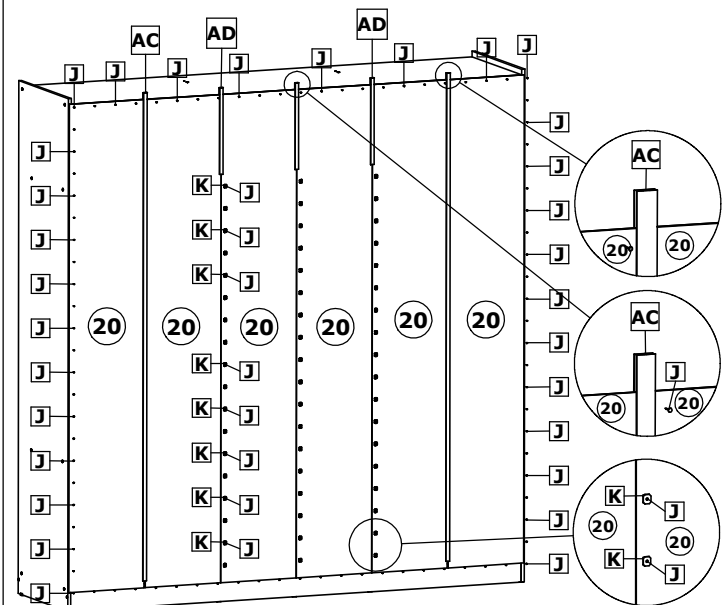

Fixar o trilho inferior ②⑥ com parafusos ②⑦, à 29mm da borda do tampo inferior ④.
 Fix the lower rail ②⑥ with screws ②⑦, at 29mm from the edge of the lower cover ④.
 Fijar el carril inferior ②⑥ con los tornillos ②⑦, a 29mm del borde de la tapa inferior ④.

5º Passo / Step / Paso

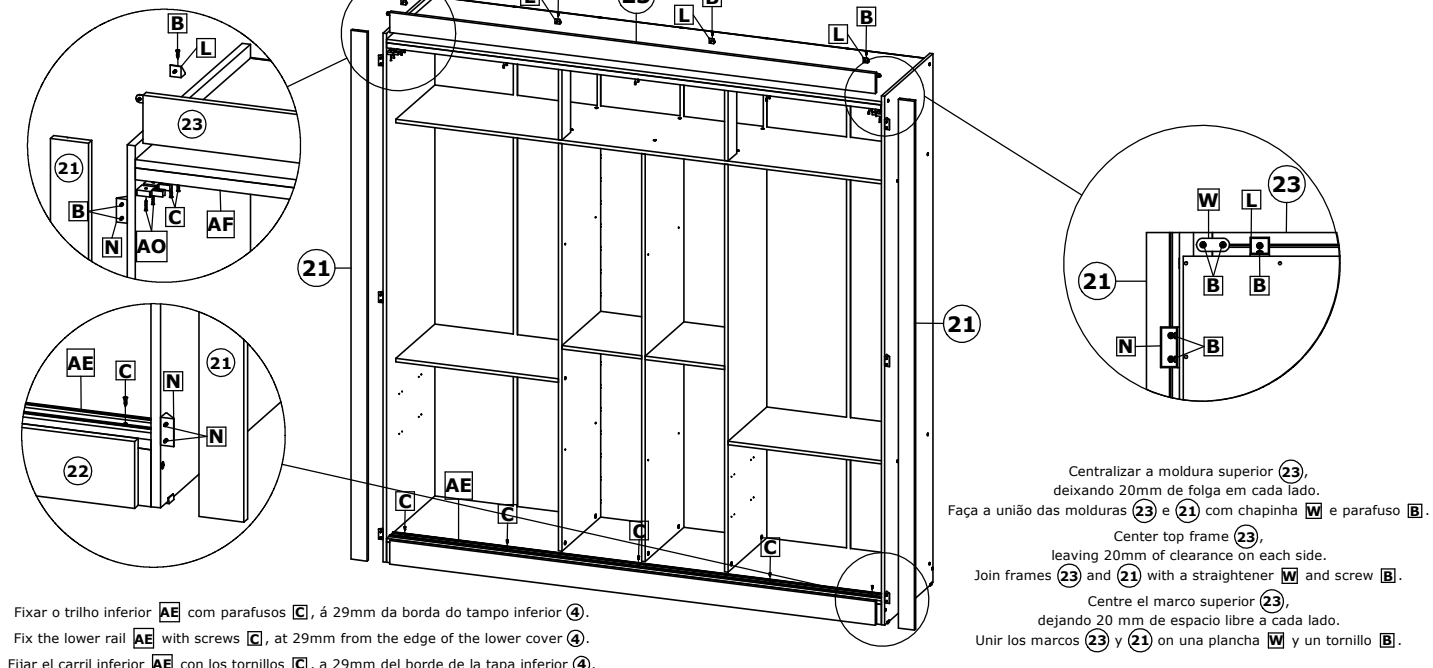

Centralizar a moldura superior ②③, deixando 20mm de folga em cada lado.
 Faça a união das molduras ②③ e ②① com chapinha ②④ e parafuso ②⑤.
 Center top frame ②③, leaving 20mm of clearance on each side.
 Join frames ②③ and ②① with a straightener ②④ and screw ②⑤.
 Centre el marco superior ②③, dejando 20 mm de espacio libre a cada lado.
 Unir los marcos ②③ y ②① on una plancha ②④ y un tornillo ②⑤.

Roupeiro Copenhagen|IBiza | Wardrobe Copenhagen|IBiza | Armario Copenhagen|IBiza.

6º Passo / Step / Paso

Fixar distanciadores **Z** com parafusos **B**.
 Em seguida fixar os trilhos telescópicos **AB** com parafusos **C**.
 Fix spacers **Z** with screws **B**.
 Then secure the telescopic rails **AB** with screws **C**.
 Fije los espaciadores **Z** con los tornillos **B**.
 Luego fije los rieles telescópicos **AB** con tornillos **C**.

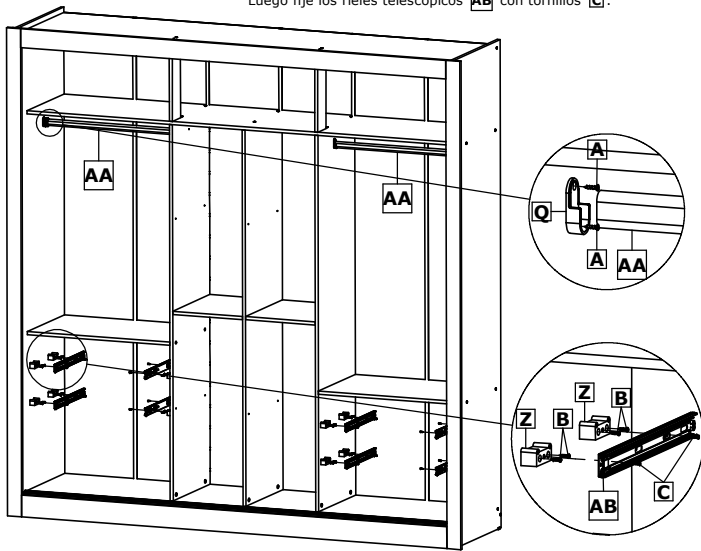

7º Passo / Step / Paso

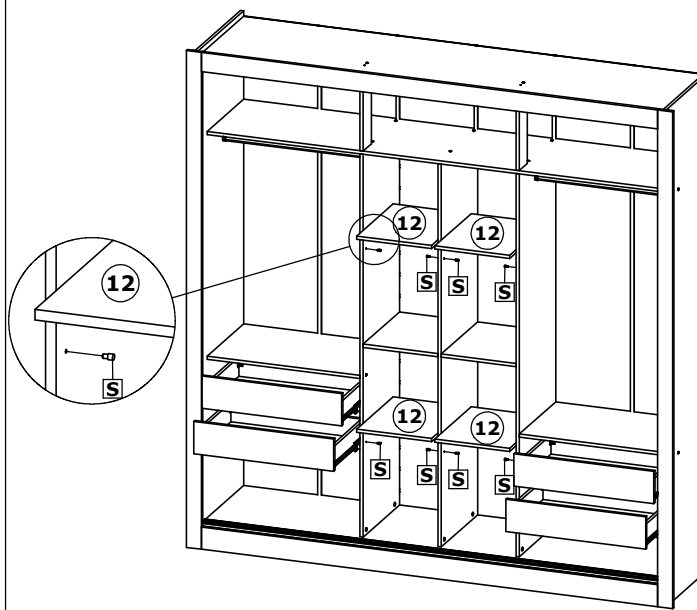

Faça a colocação das gavetas e prateleiras.
 Place the drawers and shelves.
 Coloque los cajones y estantes.

Peso Suportado / Weight supported / peso que soporta.

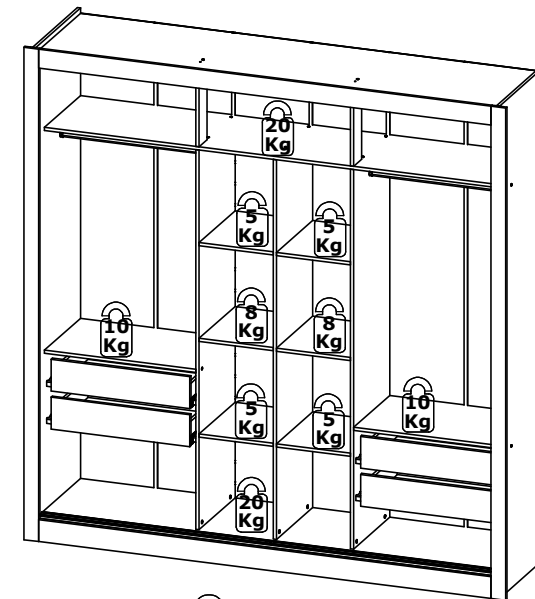

⚠ Peso Suportado por Gaveta.
 Weight Supported by Drawer.
 Peso soportado por Cajón.



8º Passo / Step / Paso

Montagem Portas Copenhagen | Copenhagen Doors Assembly | Montaje Puertas Copenhagen.

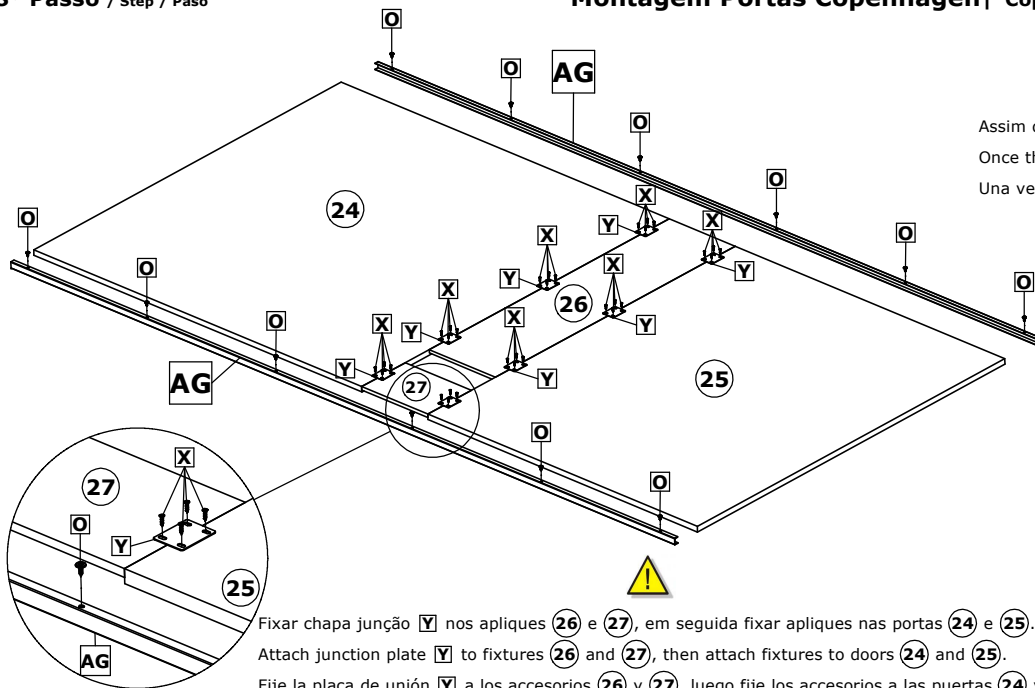

Fixar chapa junção **Y** nos apliques **26** e **27**, em seguida fixar apliques nas portas **24** e **25**.
 Attach junction plate **Y** to fixtures **26** and **27**, then attach fixtures to doors **24** and **25**.
 Fije la placa de unión **Y** a los accesorios **26** y **27**, luego fije los accesorios a las puertas **24** y **25**.

⚠ Assim que a porta estiver montada, colar o espelho **28** conforme imagem abaixo.
 Once the door is assembled, glue mirror **28** as shown in the image below.
 Una vez montada la puerta, pegue el espejo **28** como se muestra en la imagen de abajo.

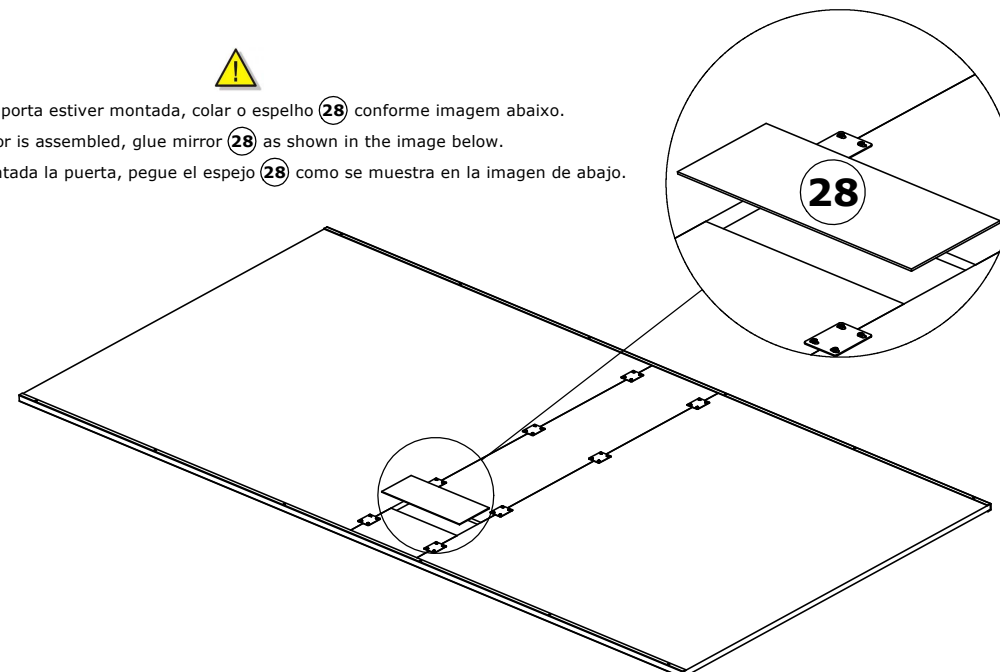

Montagem Portas Copenhagen | Copenhagen Doors Assembly | Montaje Puertas Copenhagen.

Iniciar a montagem dos guias superiores **AK**,
posicionando-os à 32mm da cantoneira U **AG**, fixando-os com parafusos **AO**.

Start assembling the upper guides **AK**,
positioning them 32mm from the angle U **AG**, fixing them with screws **AO**.

Comience a ensamblar las guías superiores **AK**,
colocándolos a 32mm del ángulo U **AG**, fijándolos con los tornillos **AO**.

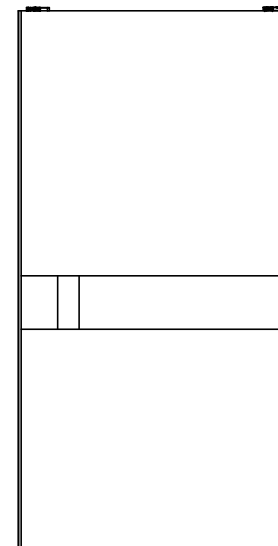
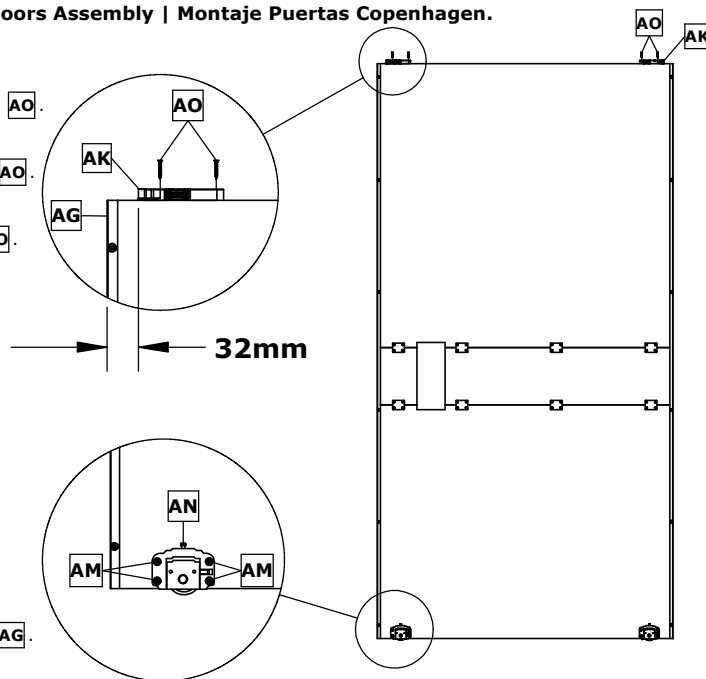

**Porta Esquerda.
Left Door.
Puerta izquierda.**

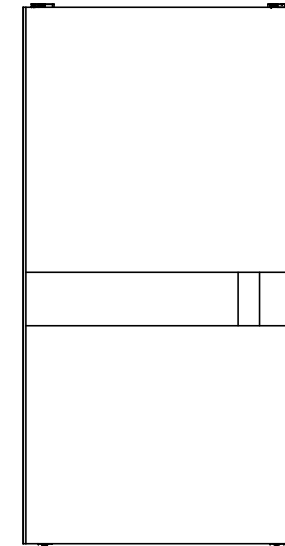

**Porta Direita.
Right Door.
Puerta derecha.**

9º Passo / Step / Paso

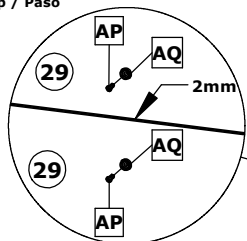

Inicie a fixação dos espelhos **29** pela parte inferior.

Alinhe o espelho **29** a cantoneira,
deixando uma distância de 46mm do topo da porta.

Em seguida fixe espelhos **29** com parafusos **AP** e suporte **AQ**,
deixando 2mm de distância de um espelho para o outro.

Start attaching mirrors **29** from the bottom.

Align the mirror **29** with the corner,
leaving a distance of 46mm from the top of the door.

Then fix mirrors **29** with screws **AP** and support **AQ**,
leaving 2mm distance from one mirror to the other.

Comience a colocar los espejos **29** desde abajo.

Alinee el espejo **29** con la esquina,
dejando una distancia de 46 mm desde la parte superior de la puerta.

Luego fije los espejos **29** con los tornillos **AP** y el soporte **AQ**,
dejando 2 mm de distancia de un espejo al otro.

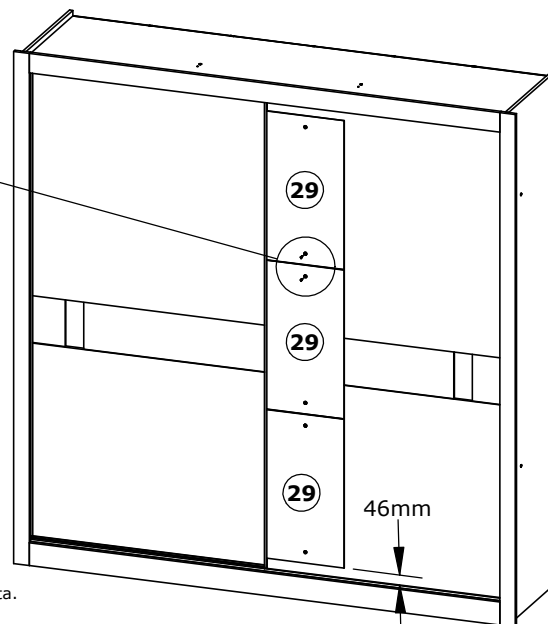

Produto Montado | Assembled Product | Producto ensamblado.

Roupeiro Copenhagen

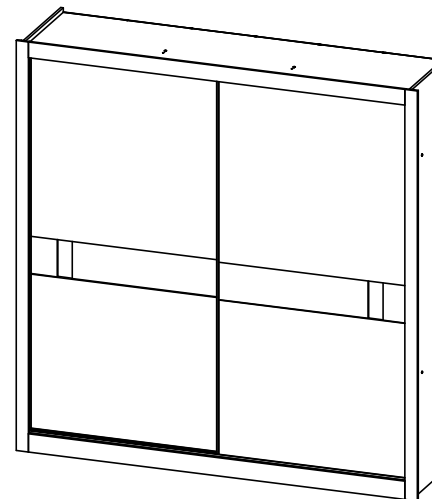

Roupeiro Copenhagen Glass

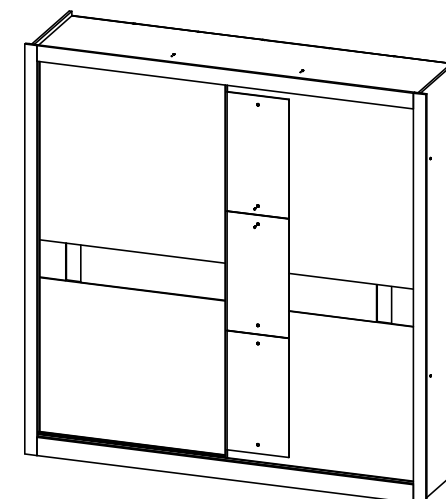

Montagem Portas Ibiza | Ibiza Doors Assembly | Montaje Puertas Ibiza.

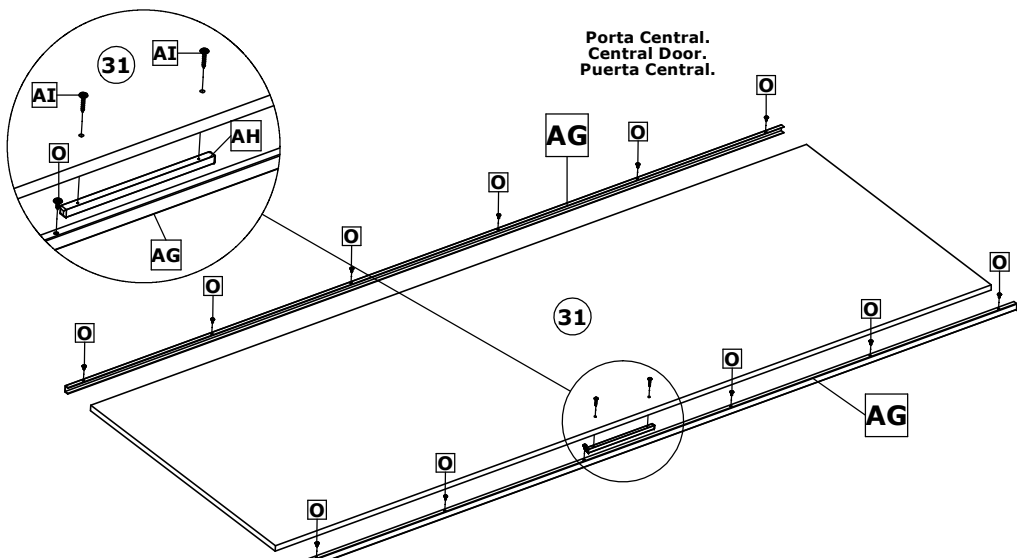

Porta Central.
Central Door.
Puerta Central.

Fixar a cantoneira **AG** com parafusos **O**, e puxador **AH** com parafusos **AI**.
Fix the angle bracket **AG** with screws **O**, and handle **AH** with screws **AI**.
Fije el soporte angular **AG** con los tornillos **O** y el mango **AH** con los tornillos **AI**.

Nas portas laterais **(30)**, utilizamos a cantoneira **AG** somente no lado do puxador **(32)**.
On side doors **(30)**, we use angle **AG** only on the side of handle **(32)**.
En las puertas laterales **(30)** utilizamos el ángulo **AG** sólo en el lado de la manija **(32)**.

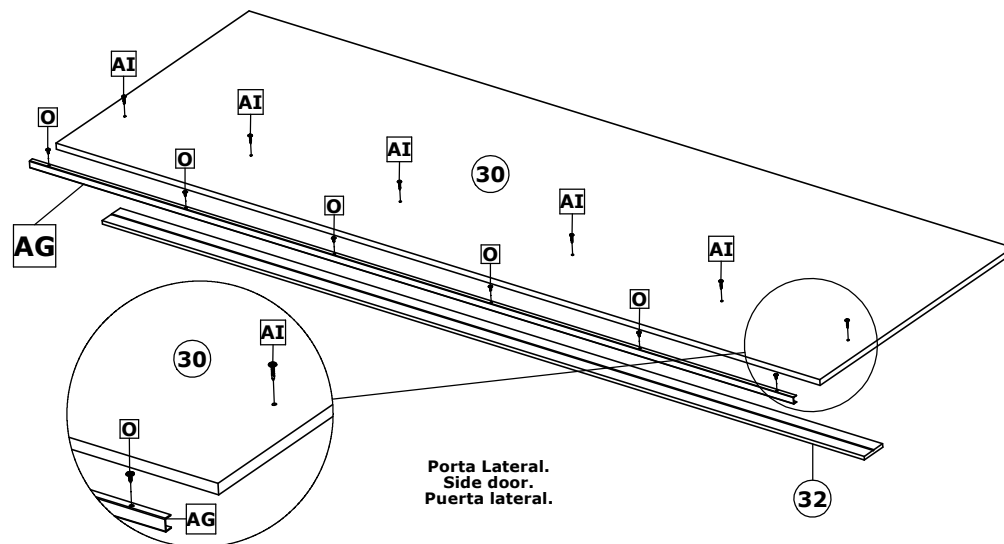

Porta Lateral.
Side door.
Puerta lateral.

Montagem Portas Ibiza | Ibiza Doors Assembly | Montaje Puertas Ibiza.

Iniciar a montagem dos guias superiores **AK**,
posicionando-os à 32mm da cantoneira U **AG**, fixando-os com parafusos **AO**.
Start assembling the upper guides **AK**,
positioning them 32mm from the angle U **AG**, fixing them with screws **AO**.
Comience a ensamblar las guías superiores **AK**,
colocándolos a 32mm del ángulo U **AG**, fijándolos con los tornillos **AO**.

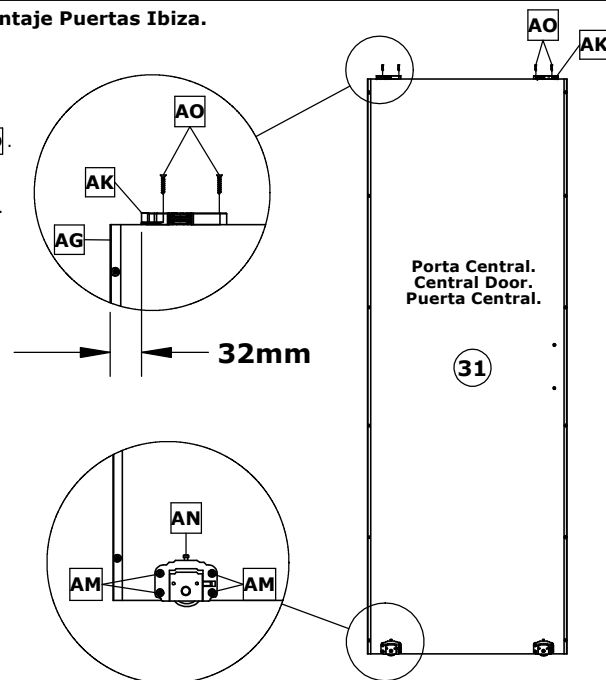

Porta Central.
Central Door.
Puerta Central.

Posicionar o rodízio inferior **AM** à 32mm da Cantoneira U **AG**.
Position the Rod Less than **AN** 32mm from the U-bracket **AG**.
Posicionar el odamiento inferior **AM** a la 32mm de la Cantoneira U **AG**.

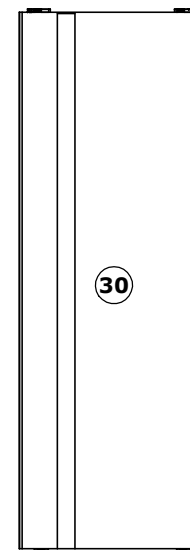

Porta Esquerda.
Left Door.
Puerta izquierda.

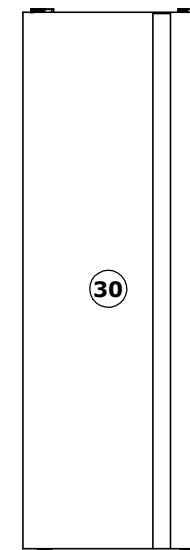

Porta Direita.
Right Door.
Puerta derecha.

Roupeiro Copenhagen|IBiza | Wardrobe Copenhagen|IBiza | Armario Copenhagen|IBiza.

9º Passo / Step / Paso

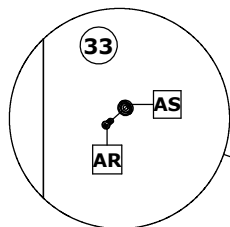

Inicie a fixação dos espelhos 33 pela parte inferior.

Posicione o espelho 33 á 146mm do topo da porta, e 69mm da cantoneira.

Em seguida fixe os espelhos 33 com parafusos AR e suporte AS, deixando 2mm de distância de um espelho para o outro.

Start attaching mirrors 33 from the bottom.

Position mirror 33 at 146mm from the top of the door, and 69mm from the angle.

Then fix mirrors 33 with screws AR and support AS, leaving 2mm distance from one mirror to the other.

Comience a colocar los espejos 33 desde abajo.

Coloque el espejo 33 a 146mm de la parte superior de la puerta, y 69mm desde el ángulo.

Luego fije los espejos 33 con los tornillos AR y el soporte AS, dejando 2mm de distancia de un espejo al otro.

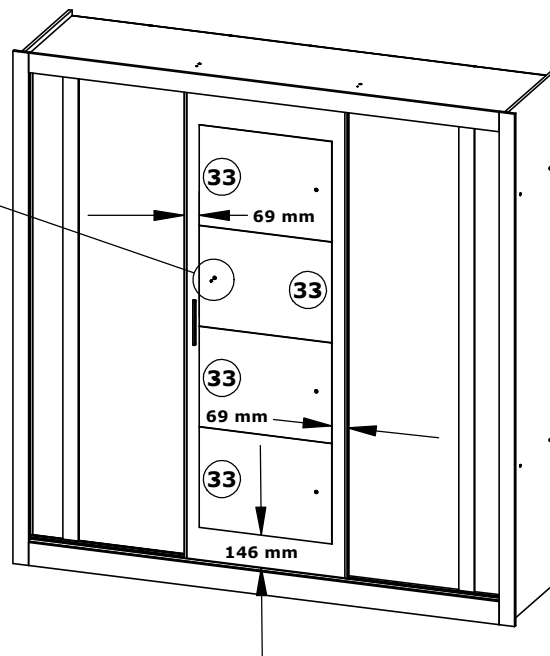

Produto Montado | Assembled Product | Producto ensamblado.

Roupeiro Ibiza

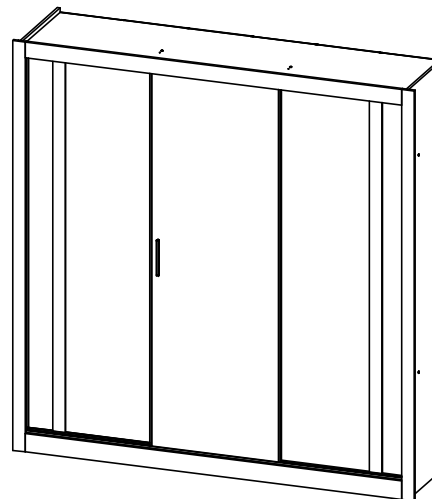

Roupeiro Ibiza Glass

